

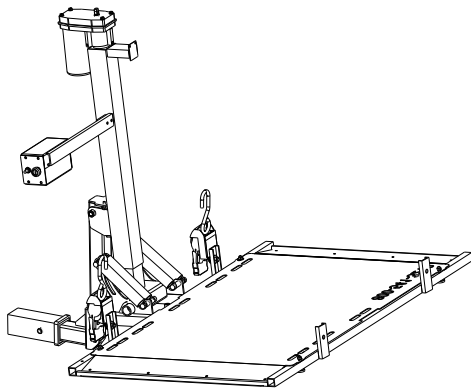

1-888-364-3813

**INSTALLATION GUIDE AND OWNERS MANUAL**



**Model J350  
Electric Lift**

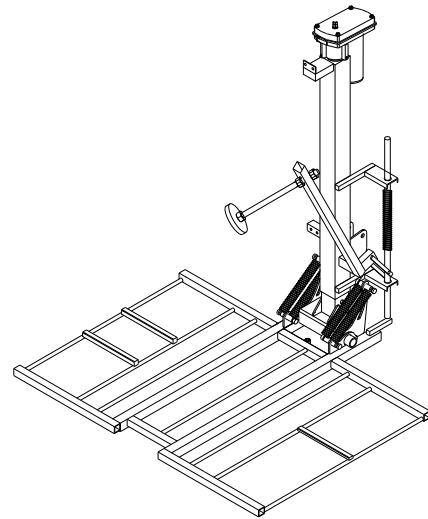

**Model J750-PL  
Challenger X  
Power Lift**

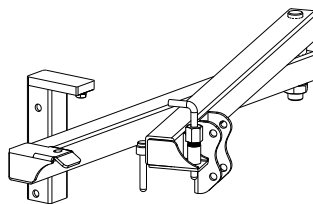

**Swing Away Option**



**CAUTION:** Read and follow all installation instructions and operating instructions before the first use of this product.

**\*\*\*Save this manual for future reference\*\*\***

# Introduction

Congratulations on your new *Top Mobility* product purchase! This manual has been written to be used as an installation guide as well as an operation/maintenance guide for the end user.

Before installing, be sure to have the proper hitch installed on your vehicle. Consult the Hitch Manufacturer for load ratings prior to operation of your lift. **Never** exceed the Hitch load rating set from the Hitch Manufacturer. The Warranty will be voided if the recommended tongue weight is exceeded. [Tongue weight: Weight of Lift + Weight of Scooter or Power Chair. See *product weights* below.]

Both installers and operators must read all of the available manuals thoroughly before attempting any installation, operation, or maintenance on equipment.

If you have any questions or comments concerning the installation or operation of this carrier, please contact your Top Mobility or Wheelchair Carrier for additional technical information.



**Caution:** Be sure that the wheelchair or scooter being transported meets the size and weight constraints set for this product.



**WARNING**  
Never exceed the weight capacity of the carrier.

## Product Specs

<i>Product</i>	<i>Weights</i>	<i>Size</i>	<i>Capacity</i>
J-750:	103lbs	28" x 48"	350lbs
J750-PL:	90lbs	23-5/8" x 37"	200lbs

\*Distance from Hitch to platform when in stow away position  
10.5" to 13.5" (15" to 18" with Swing Away)

# SWING AWAY MODEL 130 INSTALLATION PROCEDURE

The Swing Away feature can be added to a Class II [1-1/4" Square] or Class III [2" Square] hitch only. The Swing Away feature can be added to allow comfortable access to the rear of any vehicle.



**WARNING:** Scooter or powerchair must be unloaded off the platform prior to opening the Swing Away.

**Tools required:** (2) 3/4" Wrenches

**Step 1:** Carefully unpack the swing away.

**Step 2:** Attach Swing Away to hitch attachment using (2) 1/2-13 x 3" bolts and lock nuts provided. [See Fig A]

**Step 3:** Slide the Hitch Adapter into the hitch as far as it will go. Insert the Bolt into the Spacer, through the Hitch, through the Hitch Adapter and tighten using the Lock Nut. Make sure the Spacer is pushing the Hitch Adapter tight against the inside of the Hitch. This will ensure a solid connection. [See Fig B]

**Step 4:** Attach the Lift N Go to the Swing away. Secure in place using (2) 1/2-13 X 3" Bolts and Lock Nuts. Choose the two holes that allow optimum working height of carrier. [12" to 15" from ground to bottom of extended platform] [See Fig C] Note: Adjustment nut is to adjust gap between arms. If gap is too small arms will not swing apart and if too large they will have to much "play" which could cause vibration.

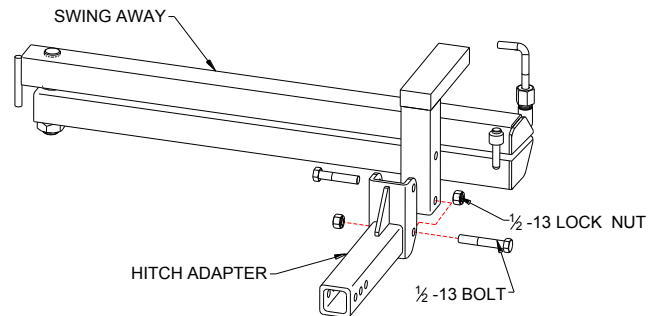

FIG A

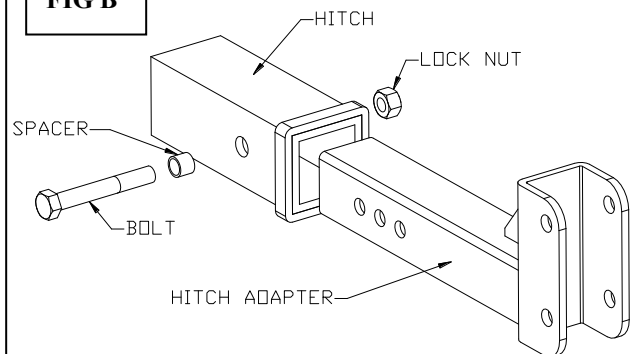
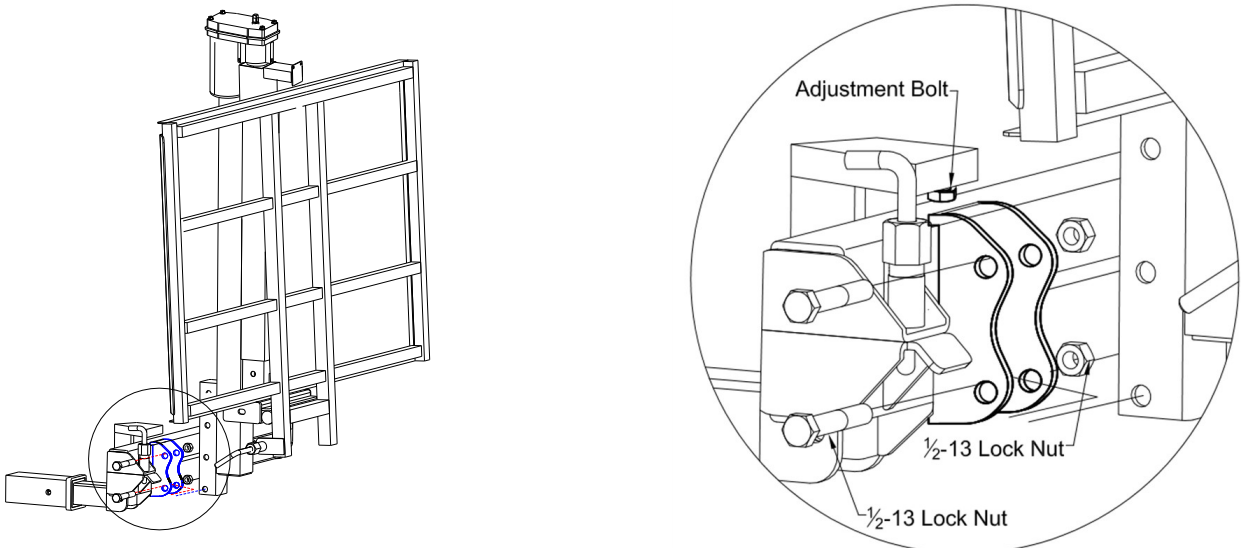

FIG B

FIG C



## SWING AWAY MODEL 130 INSTALLATION PROCEDURE [cont'd]

**Step 5:** Routing the wire harness along the Swing Away. Be sure the swing away can open and close without damaging the wire harness. Make sure the exhaust is not directly on the wire harness. [See Fig D]

**Step 6:** Secure wires with 12" Tie Straps included.

FIG D

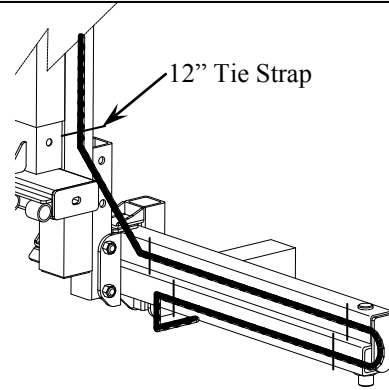

## SWING AWAY MODEL 130 OPERATION PROCEDURE

**CAUTION:** The vehicle is to be on level ground during use of the Swing Away. Failure to do so may result in operator losing control of the lift causing damage to persons and property.

### Opening the Swing Away [See Fig E]

**Step 1:** Release safety pin.

**Step 2:** Pull up on the Handle of the slam latch.

**Step 3:** While pulling up on the Handle, push the platform away from the vehicle and swing away.

FIG E

Slam Latch Handle  
Periodically grease

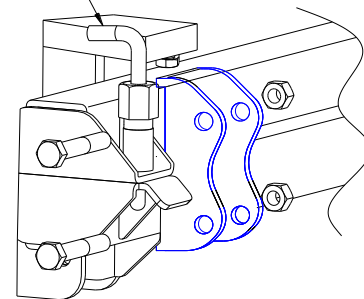

### Closing the Swing Away [See Fig F]

#### Keep clear of latch

**Step 1:** Push platform toward the vehicle and the slam latch will automatically lock the swing away in place.

**Step 2:** Ensure the Latch is fully engaged.

**Step 3:** Insert safety pin and secure.

FIG F

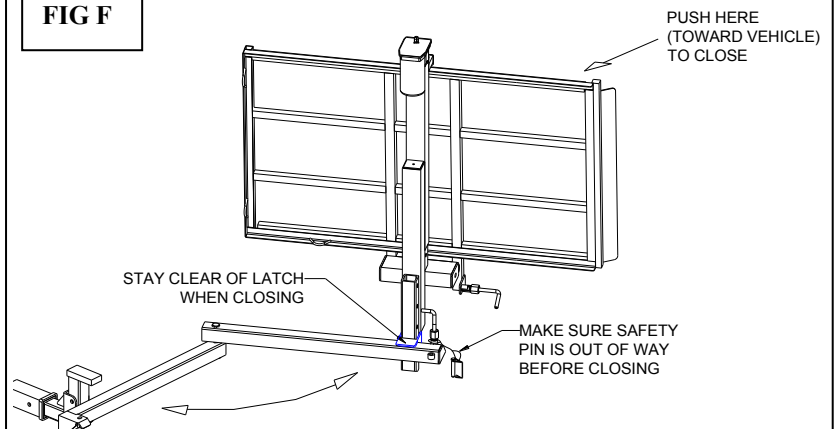

# Installation Instructions



## **Important!!**

Please refer to the diagrams while following instructions.

**Note:** A Class II [1-1/4"] or Class III [2"] hitch is needed in order to install the Carrier. Depending on your vehicle it may be necessary to install an upgraded suspension.

## Mounting

Before securing the **Hitch Adapter**, be sure to position the adapter so that it meets the dimension range shown in Fig A.

**Step 1. Pre-Install the Hitch Adapter**  
[see Fig B]

- 1) Slide the Hitch Adapter into the hitch and align the hole that allows the Adapter to achieve maximum penetration.
- 2) Keep note of the Hitch Adapter position and remove it.
- 3) Attach Hitch Adapter to the 2" Square Tube Adapter. See fig C on next page.
- 4) Slide Adapter with the lift attached into the hitch.
- 5) Insert the Bolt into the Spacer, then through the Hitch, through the Hitch Adapter and tighten using the Lock Nut.
- 6) Make sure the Spacer is pushing the Hitch Adapter tight against the inside of the Hitch. This will ensure a solid connection.
- 7) Shown in Fig B is a Class 3 Adapter [2 inch square]. Attachment of the Class 2 Adapter [1-1/4 inch square] is performed the same way with different hardware.
- 8) Height Adapter Shown in Fig C as orientated with Hitch & Hitch Adapter. **SOLD SEPARATELY**

Fig A

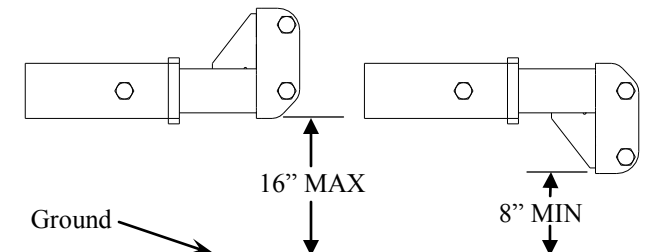

Fig B

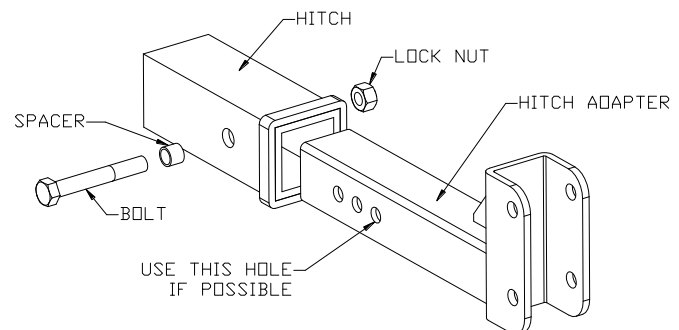
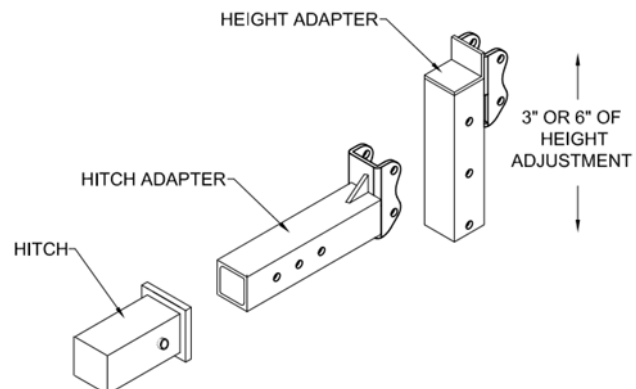

Fig C

Set-up when **HEIGHT ADAPTER** is required  
\*\*\*SOLD SEPARATELY\*\*\*



# Installation Instructions

## Step 2. Install the Platform and Post to the Hitch Adapter [see Fig C]

1) Align Tube Adapter to the Hitch Adapter and attach using the (2) 1/2-13 x 3" Grade 5 Bolts and Lock Nuts.

## Step 3. Install the Motor to the Post. [see Fig D]

1) Be sure the Motor is seated. When seated there should be approximately 1/4" of the round tube showing.  
2) Tighten the three set screws.

**[Do Not Over Tighten]**

## Step 4. Attach the Switch box [See Fig E]

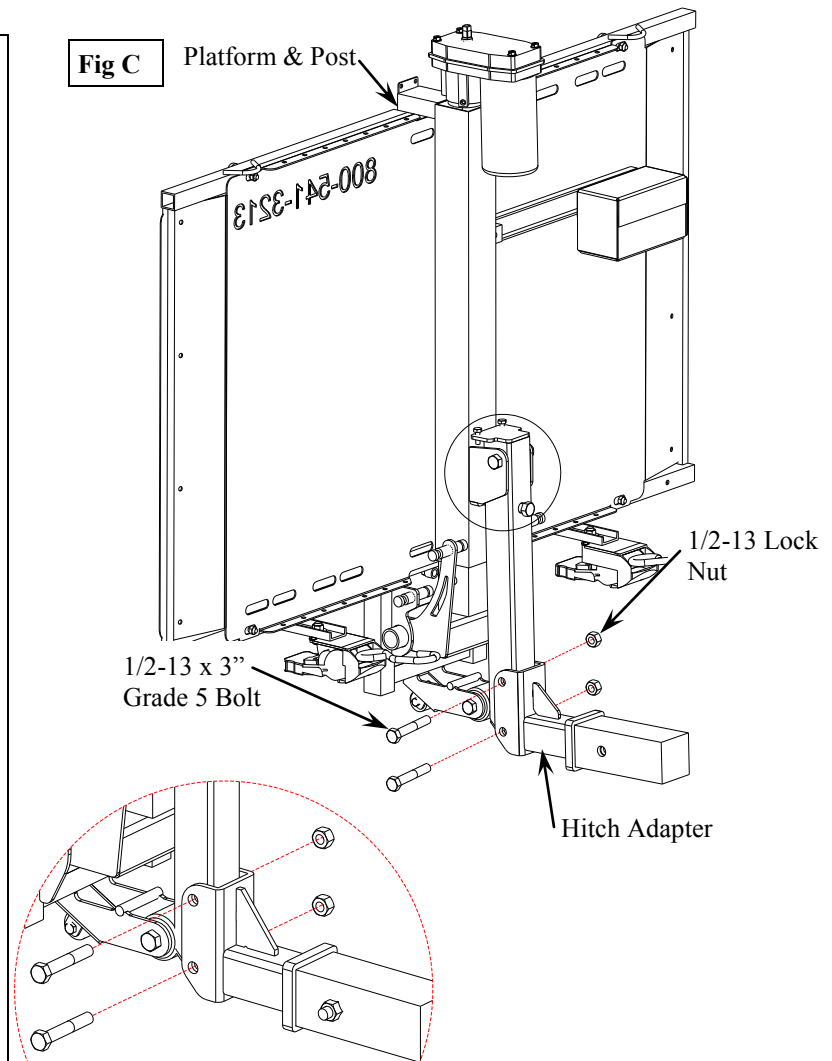

Use the Hand Crank to align the drive pin on the motor with the driven shaft of the Post

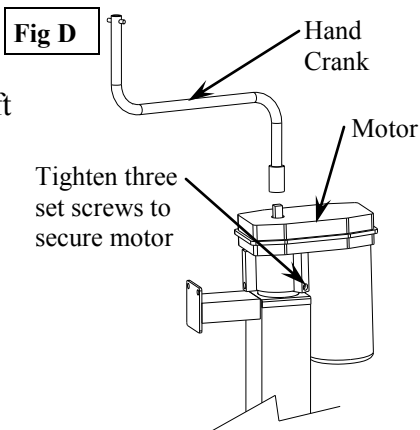

If an electrical failure should occur, the crank handle may be inserted into the motor and the lift can be operated manually.

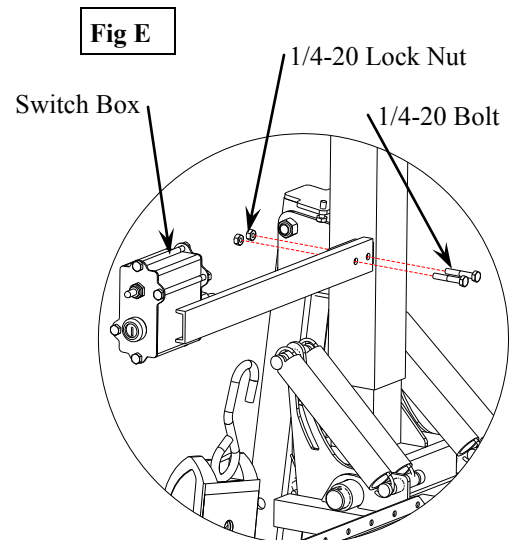

**WARNING Crank Handle: Do not push Toggle Switch with crank handle in place. This will cause serious injury.**

# J750-PL — Challenger X Power Lift

## Instruction for hold down arm

1. With the platform on the ground, drive the scooter onto the platform from left (driver's side of vehicle) until the rear wheels of scooter are positioned in one of the 3 pockets and the scooter's deck is in-line with the hold down arm.
2. Raise the platform until you hear the motor clutch, which indicates the top of travel.
3. Loosen both nuts on the hold down arm and raise or lower the foot to contact the scooter's deck. (See below)
4. Lower the platform about 1 or 2 inches.
5. Lower the foot once again to the scooter's deck and adjust nuts.
6. Raise the platform. Verify the hold down foot places adequate pressure on the scooter.
7. Once foot is properly positioned, tighten nuts.
8. Lower lift to the ground and raise it back up to transport position. Check hold down to assure it is holding scooter securely. Repeat this process a few time.
9. With platform on ground, remove the scooter. Cycle lift up and down to make sure everything is in working order.

### Notes:

On some scooters, it may be necessary to temporarily move the steering tiller forward to clear the hold down arm as it lowers into the hold-down position.

Some scooters have pneumatic (air inflated) tires. If your scooter has this type of tire, be sure they are properly inflated. Improper inflation will change the deck height of the scooter and affect the amount of clamping force the hold down arm places on the scooter. The scooter could fall off in not properly secured.

Be sure to instruct the end user to avoid entering steep driveways straight on. Enter and leave at an angle to the street so that the lift platform does not drag the ground.

### Caution:

Drive the scooter off in REVERSE. When the scooter is clear of the platform, raise the platform.

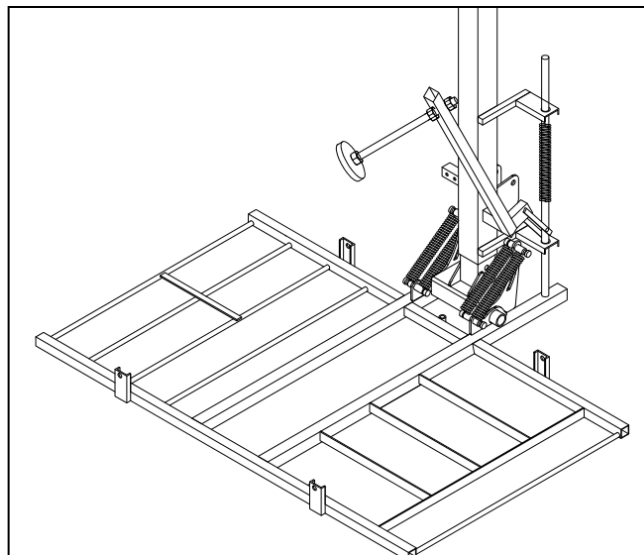
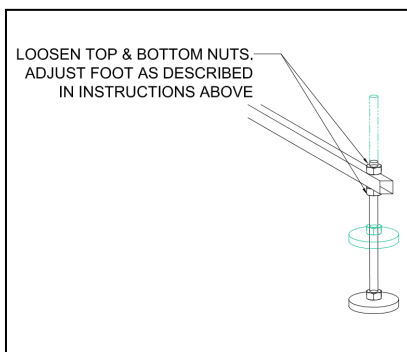

# Installation Instructions

**WARNING: Disconnect the battery before attempting the wire installation!**

**Step 4. Wire the Lift directly to the vehicle's battery.** [see Fig E]. The wire harness for the lift has a 30 Amp Automatic resettable circuit breaker in line of the power wire, therefore the motor **must** be connected directly to the battery. [The circuit breaker will reset within 20 seconds if it is tripped]

1) Route the wire harness down through the engine compartment and to the rear of the vehicle. The wire harness consists of (2) 10 Ga. wires 21 feet in length.

2) **Avoid moving parts such as carburetor linkages, steering parts, fans, belts, and pulleys. Also avoid hot parts such as exhaust manifolds & pipes.** (Use tie straps to secure the wire.) Attention to detail will keep the wires safe from cuts and scrapes and from interfering with the vehicle operations.

3) Be sure that all connections are secure. Coil any unused length of wire and secure safely under the vehicle.

4) To help keep the terminals clean, be sure to cover them when not in use to avoid contamination. Dielectric grease should be used to help avoid corrosion.

Fig E

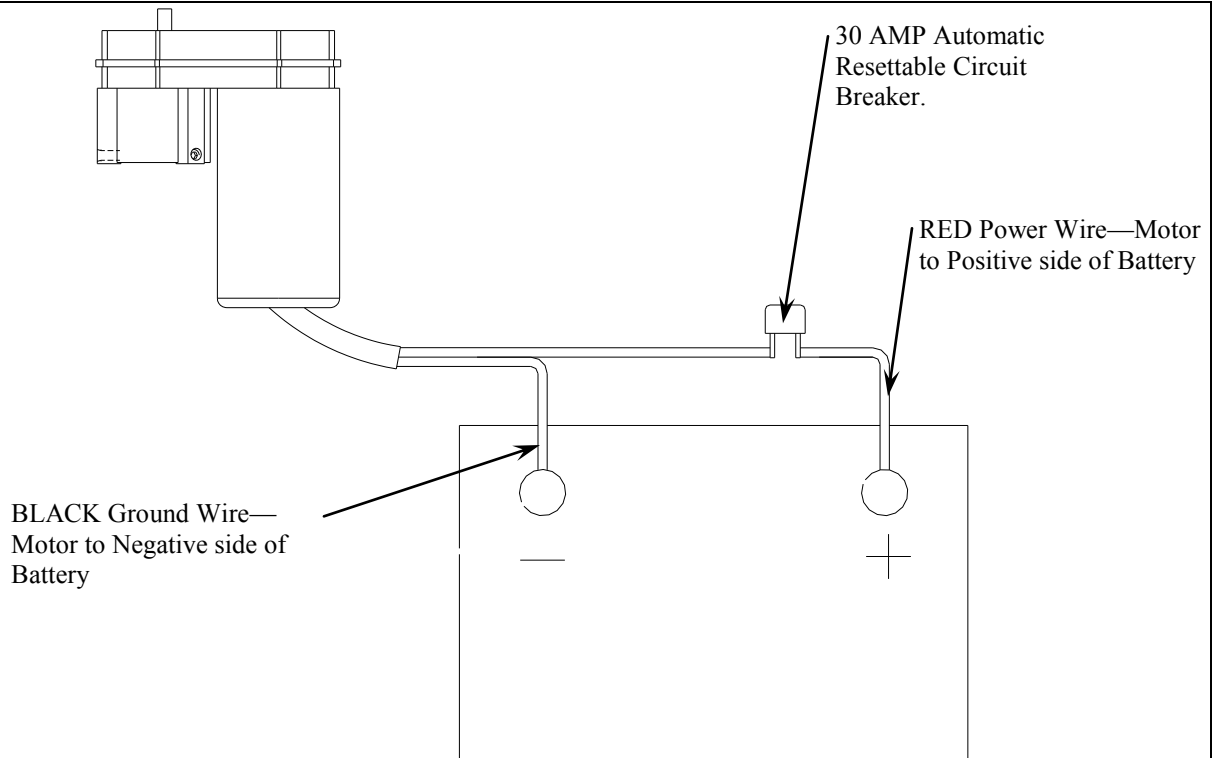

**NOTE:** The 4 way connector is only used with the optional License Plate Kit



# Operation Instructions

- To lower the Platform to the Transport position, turn the key to the on position then press and hold the Motor Switch down [see Fig F]. While staying clear of the platform continue holding the Switch down while the platform falls away from the post and transitions flat on the ground. [see Fig G,H & I]
- Load the Power Chair or Scooter onto the Platform.
- Remove yourself and all loose objects from the platform and chair before raising the platform.

Stow Away Position

Fig F

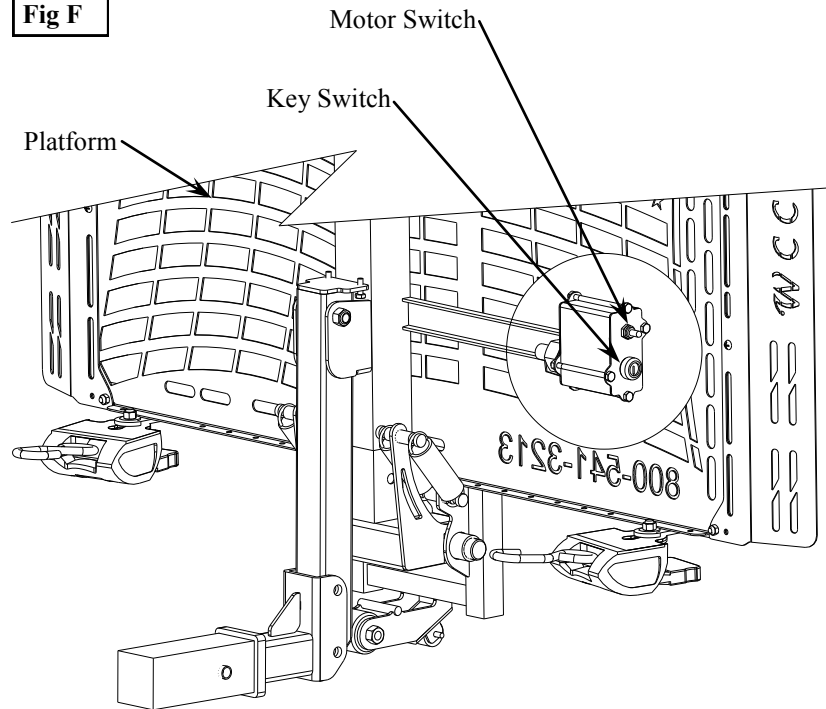

Fig G

**\*Platform Must rotate down**

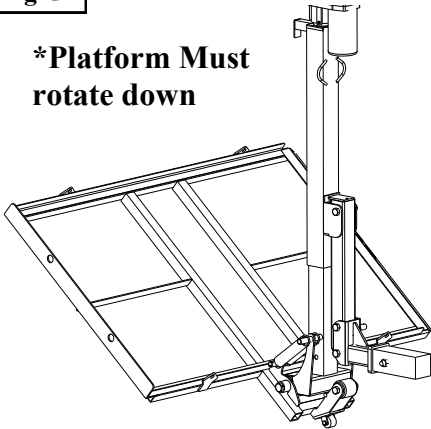

Fig H

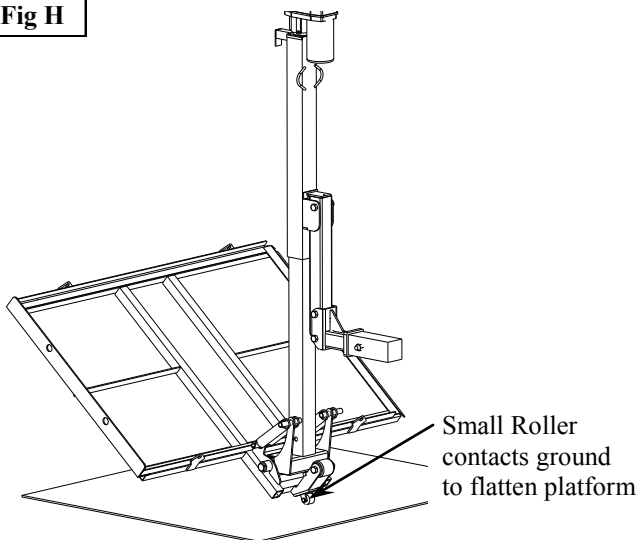
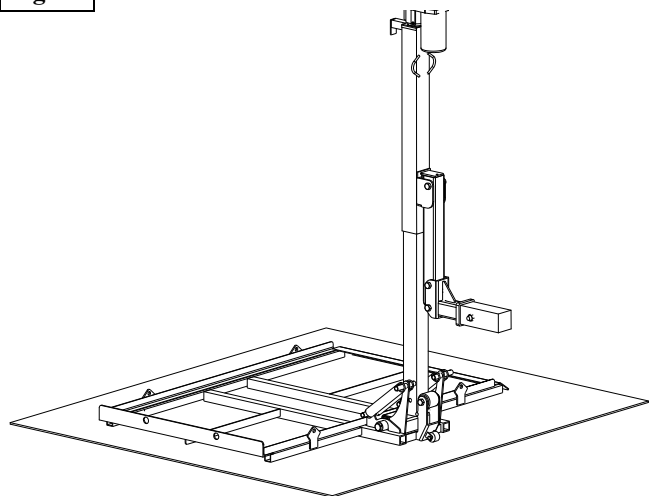
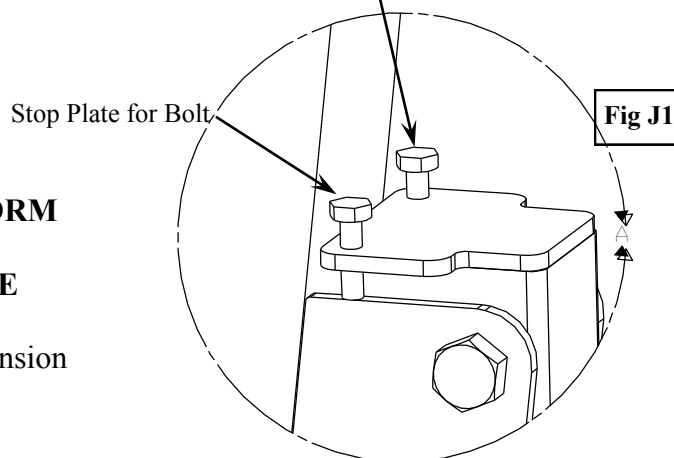
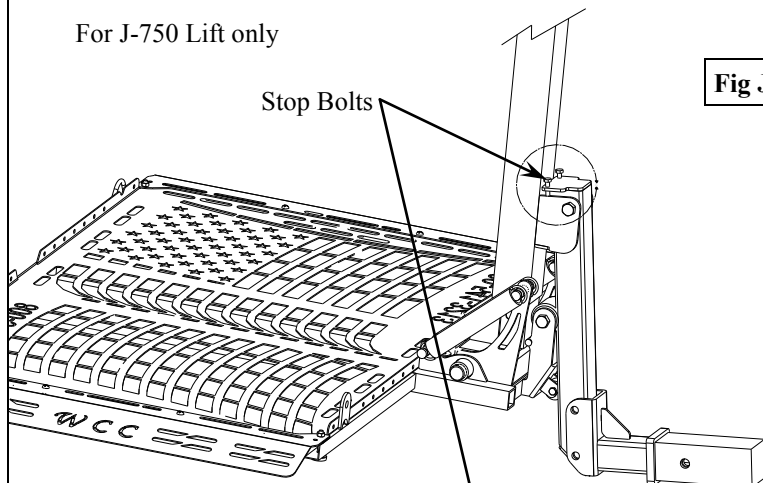

Fig I



# Operation Instructions

- Load the Power Chair or Scooter onto the Platform.
- Raise the Platform approximately halfway up by pressing and holding the Toggle Switch upwards.
- Secure the cargo to the platform with the Ratchet Straps provided. *See Securing the Chair to the Carrier on pg8.*
- Raise the Platform up until it is tight against the stop bolts. [see Fig J] Stop bolts must always be touching its stop plate when in the transport position. [see Fig J1] **Do not over tighten the stop bolts. Over tightening will cause damage to the Post.**



Transport Position [Shown in Fig J]

**CAUTION: DO NOT LOWER THE PLATFORM WHILE IN THE TRANSPORT POSITION WITHOUT A MINIMUM OF 25 LBS ON THE PLATFORM!**

If platform is lowered without weight on it, the tension of the springs will swing the platform up quickly.

**Remember to keep hands and feet away from moving parts during operation.**

When the Motor reaches the end of its travel a built in torque limiter goes into operation with a clicking noise. This torque limiter permits the final drive gear to slip and thus protects the unit. **Prolonged operation of the torque limiter is NOT recommended.**

If an electrical failure should ever occur the crank handle may be inserted onto the post and the power post can be raised or lowered manually.

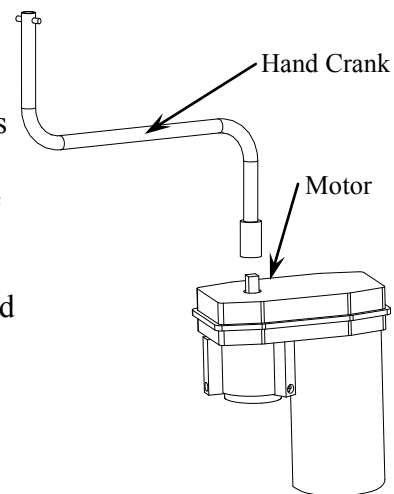

**WARNING Crank Handle: Do not push Toggle Switch with crank handle in place. This will cause serious injury.**

# Securing the Chair to the Carrier

## RETRACTABLE RATCHET IN- STRUCTION

### **Release Strap:**

Pull down on the Release Lever and rotate the Ratchet Handle up. While in this position the strap is loose and can be extended much like a seatbelt. *(Both sides of the retractor spool may be lubricated, as needed.)*

### **To Hold Chair:**

Attach the S-hook to the opposite side of the platform while in the Release Position. To avoid damage take caution as to where the chair will be secured.

### **To Tighten:**

Pull down on the Release Lever and rotate the Ratchet Handle down to the Ratchet Position. At this point the Ratchet Handle can be used to tighten the strap. Do not over tighten. After the chair is secured the Ratchet Handle must be pushed down into the Lock Position.

### Lock Position

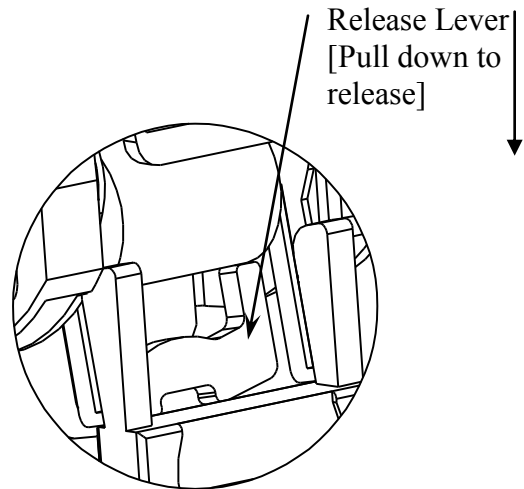
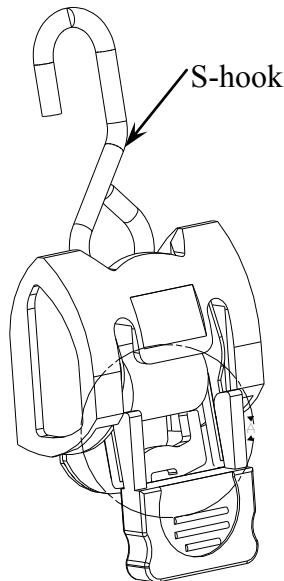

### Release Position

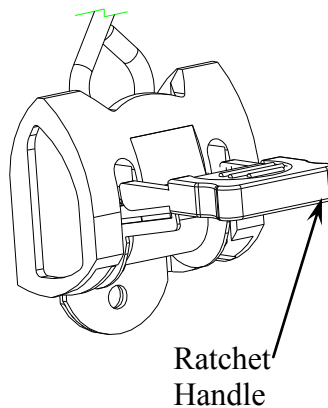

### Ratchet Position

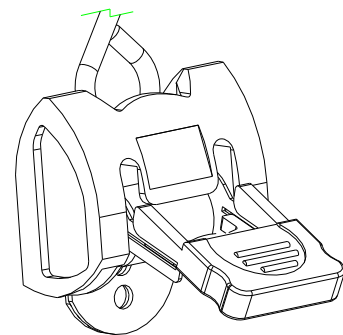

**CAUTION:** Do not over-tighten straps or damage to chair could result. Do not attempt to modify your carrier in any way. **This will void your warranty.**

# Maintenance

Our carriers have been designed to be as trouble free as possible for the owner. However, as with any mechanical device, maintenance should be performed regularly while owning and operating our carriers.

Schedule a preventative maintenance inspection at least once a year on the carrier frame and all moving parts of the carrier.

Regularly check and tighten all hardware on the carrier.

Regularly check for paint chips and touch up any bare metal with a quality gloss black enamel or lacquer to inhibit rust.

Every 6 months lower the post and clean off any debris from the inner (silver) square post. After cleaning, apply some white lithium grease to keep friction from the two post at a minimal. While the post is still in the lowered position, spray white lithium grease inside the 1/8" holes located approximately 2" from the bottom of the motor housing, raise and lower lift while spraying grease. (Inside these square tubes, a bearing is located and maintaining lubrication on this surface will help prevent the lift from sticking or continuously clutching out without movement.)

The number one issue over time is the electrical connections to the lift. Any corrosion at the connections or at the battery will cause resistance in the power supply to the motor. If this happens you will notice the motor gradually becoming weaker. To prevent this from occurring, clean out all connections and make sure the steel terminals are in good shape. Apply a generous amount of "Anti-Oxidant Compound" to all connections.

**WARNING:** Make sure the power supply is off to prevent any shock from the 12 volt system. Always have a certified Wheelchair Carrier Service Representative assist in this operation.

Always maintain a strong performing battery, over time the vehicles battery could become weaker and a replacement would be needed to keep the motor performing at a maximum. A weaker smaller battery will prevent the motor from working at its peak.

## Trouble Shooting Lift Wiring & Motor Issues

1. Check each connection by pulling gently to make sure everything is still tight and the wires are not damaged.
2. Clean and tighten connections that are loose or dirty. (This is the #1 cause for poor lift performance. The motor needs to work at its full capacity. Any break in wiring connection will slow motor or cause it to operate intermittently which causes premature motor deterioration.
3. Inspect the lift's wiring harness running through or under vehicle for damage, such as torn insulation jacket. The harness is subject to road debris or rubbing against vehicle frame which can cause it to short. If damage is found order new wiring harness.
4. A circuit breaker is located about 6" away from the vehicle battery connect on the harness. The circuit breaker resets itself if over loaded. However, verify the breaker if functioning, if not replace it with a new one.
5. To check motor on power head, disconnect wire plugs and loosen the three set screws attaching the motor to the post so power head will come off. Using a 12 volt power supply, (such as a 12 volt battery instant start charger) connect to the weather poof plugs of the power head. Note: The motor will turn immediately once power is supplied.
6. Reverse the positive and negative connect to the power head to reverse the motor. If motor does not work a replacement motor may be needed. If the motor turns, replace it on the lift post and secure the three set screws (DO NOT OVER TIGHTEN - Over tightening will cause housing to crack).
7. Now place scooter/power on lift and repeat the power head test with 12 volt power source. If motor struggles a new motor may be needed.

Note: All weatherproof connections must have the male and female plugs securely attached and in good condition. Thoroughly apply a covering of electrical grease twice a year.

# Troubleshooting Guide

Problem:	Like Causes:	What to do:
Motor will not work –or– Motor works intermittently	Circuit Breaker Tripped Grounding issue or loose connection	The Circuit Breaker will reset within 20 seconds. Check the ground and power wires making sure they are securely attached to the vehicles battery. Check the wires connecting to the toggle switch in the motor housing. Also check the motor housing for any cracks or damage.
Motor works but does not lower the lift	The Drive Gear may be damaged Drive Gear may be disengaged.	Using the manual hand crank, turn the shaft on the post located under the plastic cap of the motor. This may allow the gears to re-align. Call dealer or manufacturer for a replacement gear. The gears can be inspected inside of the motor to determine if they are worn or damaged.
Lift is noisy	Actuator Post may need lubricated	Locate the small hole on the post below the motor. Use a White Lithium lubricant and spray inside of post, operate and repeat. See Fig K below

**Fig K**

**DO NOT REMOVE  
THE (4) SET SCREWS!!!  
REMOVAL COULD  
VOID WARRANTY  
See Note Below**

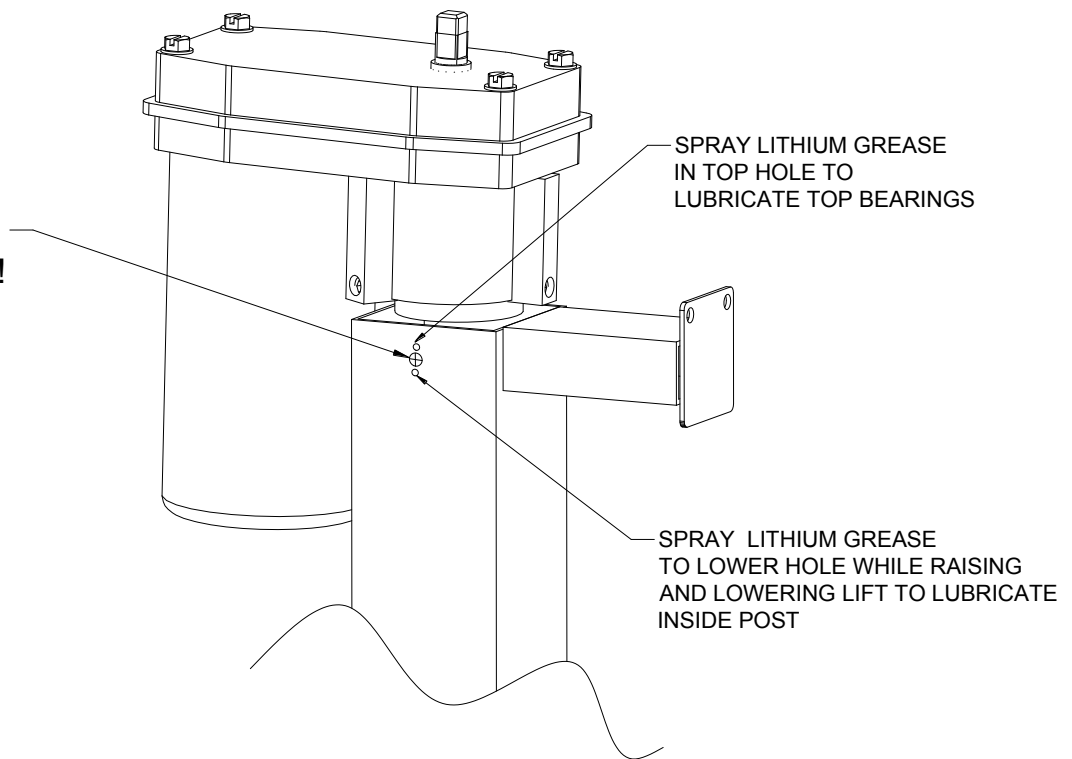

**NOTE:**

REMOVAL OF THE (4) SET SCREWS WILL CAUSE WHOLE UNIT TO DROP WHICH COULD CAUSE PERSONAL INJURY OR MAJOR DAMAGE TO LIFT AND VOID WARRANTY . ONLY A CERTIFIED TECHNICIAN SHOULD REMOVE THE SETSCREWS WHEN REQUIRED.

# Safety

**CAUTION:** Do not operate our carriers without being satisfactorily instructed in the proper operation of carrier by the dealer or without reading operation manual thoroughly.

- Our wheelchair carriers have been designed and engineered for years of trouble free performance. Although with everyday use some parts may become loose or worn. Regularly inspect your carrier for any worn, loose, or damaged parts. If you find anything upon inspection, **DO NOT USE THE CARRIER!** Contact your **Top Mobility** or WheelChair Carrier for any repairs that need to be made. **Failure to act may cause severe injury!**
- Our wheelchair carrier should only be used for the loading and unloading of wheelchairs or scooters for which it is designed. **DO NOT** add or modify any part of the carrier system without first contacting the manufacturer of the carrier. Any modifications may void any warranties as well as compromise the structural integrity of the carrier.

 **WARNING** Avoid serious injury, or death, to yourself and others. Follow all instructions in this manual.

- Before loading scooter or power chair, the vehicle must be safely parked, on a flat level surface.
- Before and during transporting, scooter or power chair must be secured to the platform and the platform must be all the way up. Check all straps regularly.
- If the scooter or power chair is not on the platform, then the platform must be in the stow away position.
- Do not exceed the weight capacity of 350 lbs.
- Keep all objects and people clear from underneath the platform at all times.

## **LICENSE PLATE BRACKET (Optional)**

Some states require the license plate to be visible at all times. When carrying a large scooter or power chair it is possible for the license plate to be covered. Be sure to know the laws governing license plates in your area.



### 3 Year Transferable Limited Warranty

Every effort has been made to insure high quality in material and workmanship of our products. Manufacturer warrants all products to be free of defects in material and/or workmanship for three (3) years from date of original purchase.

**EXCEPTIONS:** 1 year warranty on all Electrical components including motor and actuator. All custom orders have a 90~day warranty. Model 015, The Manual Carrier carries a 1 year warranty only.

**CARRIERS:** All carriers are warranted to be free of defects in material and/or workmanship for three (3) years from date of original purchase when used in accordance with manufacturer installation and operating instructions. This warranty does not cover damage due to abuse, misuse, accident, or use of unauthorized attachments or modifications. Protective finish coating on carriers is not guaranteed in as much as the manufacturer is not responsible for the use (abuse or natural wear and tear) of the product. The manufacturer and/or selling agents of carriers will not be responsible in any way for damage to, or loss of, item(s) being carried or falling from carriers or damages said item(s) may cause on or off carriers. All shipping charges for parts under warranty must be prepaid by the customer.

**TRANSPORT COVERS:** Transport covers are guaranteed free of defects in material or workmanship for one (1) year from time of purchase. Covers are not guaranteed against rips, holes, or damage due to improper installation, abuse, misuse, alteration, or environmental factors beyond our control.

### RETURN POLICY

All returns must be made within 30 days from the date of purchase unless due to defect. Written authorization **MUST** be obtained from *WheelChair Carrier, Inc.* prior to the return of any merchandise for any reason, and all transportation costs must be prepaid. **NO RETURNS** on custom orders. Authorized returns for credit only are subject to a 25% restocking charge, plus any cost incurred in restoring the merchandise to a resalable condition. Freight charges cannot be credited.



*WheelChair Carrier*

**WHEELCHAIR CARRIER, INC.**

**7325 Douglas Rd.**

**Lambertville, MI 48144**

**PHONE: (734) 568-6084 or call toll free at 1-800-541-3213**

**FAX: (734) 568-6705**

**[www.WheelChairCarrier.com](http://www.WheelChairCarrier.com)**