

## Table of Content

### Introduction

Practice before operating .....	2
---------------------------------	---

### Safety Instructions

Safety considerations .....	4
Driving Outside .....	5
Driving on various terrains .....	7

### Familiarize yourself with your power wheelchair

Feature Diagram .....	9
General Specifications Data .....	10
Assembly and Disassembly .....	11

### Adjustment for comfort

a) Adjustment of Footrest height .....	12
b) Adjustment of Armrest height .....	12
c) Adjustment of Joy - Stick .....	13
d) Climbing curbs (curb rider option only) .....	13

### Operation

a) Controls and Indicators .....	14
b) Let's GET moving .....	14
c) Driving, Steering and Braking .....	16
d) Pushing the Power Chair by Hand .....	18
e) Footrest Removal Instructions .....	19
f) Side Panel / Armrest Flip - up .....	19
g) Backrest Removal Instructions .....	20
h) Shutdown .....	20
i) Getting Ready for Permanent use .....	20

<b>Batteries</b> .....	21
------------------------	----

<b>Battery Charging</b> .....	23
-------------------------------	----

<b>Folding the Wheelchair</b> .....	24
-------------------------------------	----

<b>Curb Rider Installation</b> .....	25
--------------------------------------	----

<b>Import and Safety Information</b> .....	26
--	----

### Maintenance

a) Rear Wheel .....	35
b) Front Wheel .....	35
c) Pneumatic Tire Inflation (Hand Pump for emergency) .....	35

<b>Trouble - Shooter Guide</b> .....	36
--------------------------------------	----



## Introduction

Welcome aboard your new MP-1A powerchair and thank you for choosing our product. This latest model has been designed with specific practical user needs in mind. It combines solid rugged construction and modern high-tech electronics, safety and performance.

The MP-1A powerchair has a programmable electronic control system reflecting the latest state of the art design. It means, among other things, that your powerchair can be programmed and adjusted within a given range of its performance characteristics, to suit your individual needs and wishes. The controller is set at the factory to give the powerchair nominal operating performance characteristics.

If after an initial trial period, when you have familiarized yourself with your powerchair, you would prefer certain features to be more adapted to your personal requirements (e.g. acceleration, deceleration, maximum speed, cornering speed, response to joy-stick movement, etc.) Please contact your local dealer. He will be able to advise you, and he has the necessary equipment to carry out any adjustments required.

We recommend that your powerchair is serviced by your local dealer every six months. It is in your best interests, not only to ensure your personal safety but also to ensure long life and reliability. Please ensure that your service schedule (at the rear of this booklet) is signed by your dealer after each service.

This manual contains some useful tips and information on safety, operation and maintenance. Please read it carefully to ensure that you get maximum enjoyment and benefit from your new independence and mobility.

Whenever you require special advice and attention, do not hesitate to contact your local dealer. He has all the equipment and know-how to provide expert service. You are his customer as much as ours and he wants to see you satisfied.

Please complete and return the enclosed guarantee form.

**Failure to follow these instructions may result in damage to the powerbase wheelchair or serious injury.**

## ■ Practice Before Operating

Find an open area such as a park and have an assistant to help you practice until you have confidence operating this vehicle.

Make sure that the power is off before getting in or out of the seat. Set the speed control button according to your driving ability.

**We recommend that you keep the speed control at the slowest position until you are familiar with the driving characteristics of this vehicle.**

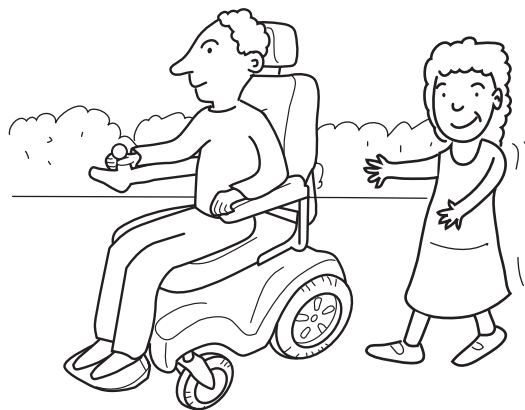

## Getting familiar with this vehicle

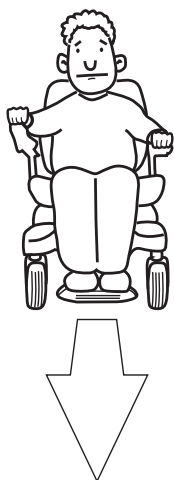

**First, practice moving forward.  
Be sure to set the speed to the lowest setting.**

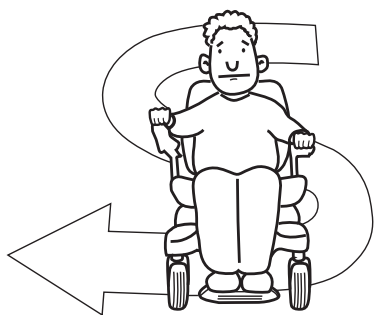

**After becoming familiar with moving forward, practice marking "S" turns.**



**Once you are familiar with "S" turns, practice moving in reverse. Note that for any speed control setting, the vehicle moves more slowly in reverse than forward.**

# Power Wheelchair User's Manual

## ■ Safety Considerations

DO NOT do any of the following



**NO!**

Do not carry any passengers



**NO!**

Do not drive across a slope



**NO!**

Do not drink and drive  
Consult your physician to  
determine if your medications  
impair your ability to control this  
vehicle



**NO!**

Do not tow a trailer



**NO!**

Do not turn on or use hand-held personal  
communication devices such as citizens band(CB)  
radios and cellular phones

## ■ Driving Outdoors

When you are on the road, please pay attention to the following:



**NO!**

Do not drive in traffic.



**NO!**

Do not drive beside a river, port, or lake without a fence or railing.



**NO!**

If possible, do not drive during the rain.



**NO!**

If possible, do not drive during or on snow.



**NO!**

Do not drive off-road or on any uneven surfaced roads.



**NO!**

If possible, do not drive at night.

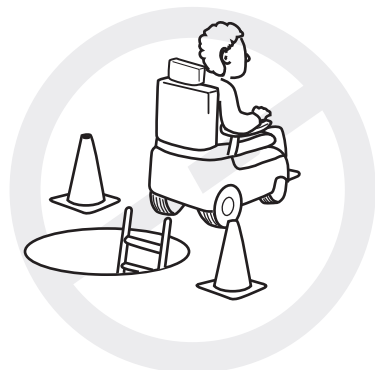

**NO!**

Make sure that there are no obstacles behind you when in reverse.

We recommend to set up the speed at the lowest setting for reversing.



**NO!**

Do not make sudden stops, weave erratically, or make sharp turns.



**NO!**

Keep your arms on or inside the armrests and feet on the footrest at all time.

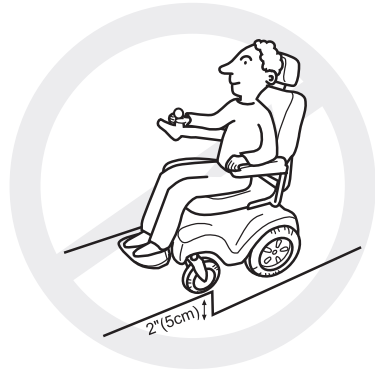

**NO!**

Do not attempt to climb curbs greater than 2"(5cm).

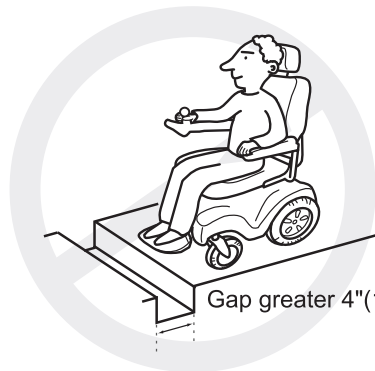

**NO!**

Do not attempt to cross over a gap greater than 4"(10cm).

## ■ Diving on Various Terrains

Driving on hills is more dangerous than on level surfaces. If you fail to heed these warnings, a fall, tip-over or loss of control may occur and cause severe injury to the vehicle user or others.



**NO!**

Do not attempt to climb a hill greater than 10°



**NO!**

Do not reverse while driving up a hill.

Forward only. If you reverse while moving up a hill, it may cause the vehicle to tip over.



**NO!**

Do not attempt to drive across a sloping surface greater than 3°

Driving across a slope greater than 3° is very dangerous and may cause the vehicle to tip over.



**NO!**

Do not drive over soft, uneven or unprotected surfaces such as grass, gravel and decks.



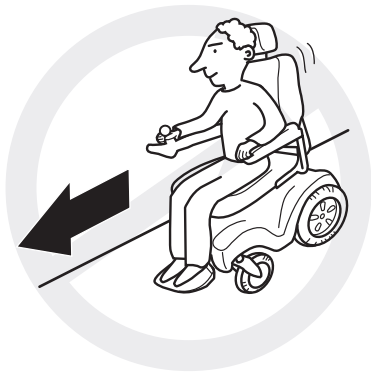

**NO!**

**Use low speed while driving down hill.**

When braking while moving down hill, the wheelchair will take longer to come to a complete stop.



**NO!**

**Do not get on and off on a hill.**

Always stop on the level surface to get in and get out of the vehicle.

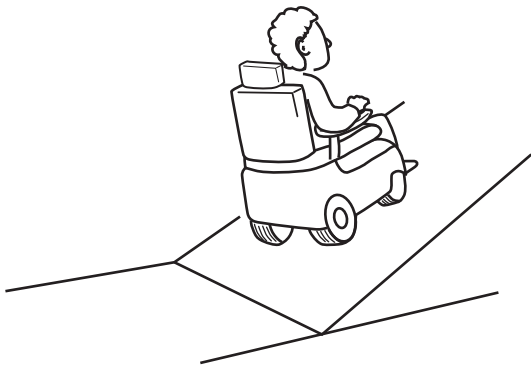

**YES!**

**Always climb or descend gradients perpendicular to the slope or ramp.**

## Familiarize Yourself With Your Power Wheelchair

### ■ Feature Diagram

#### MP-1



#### MP-1 LX

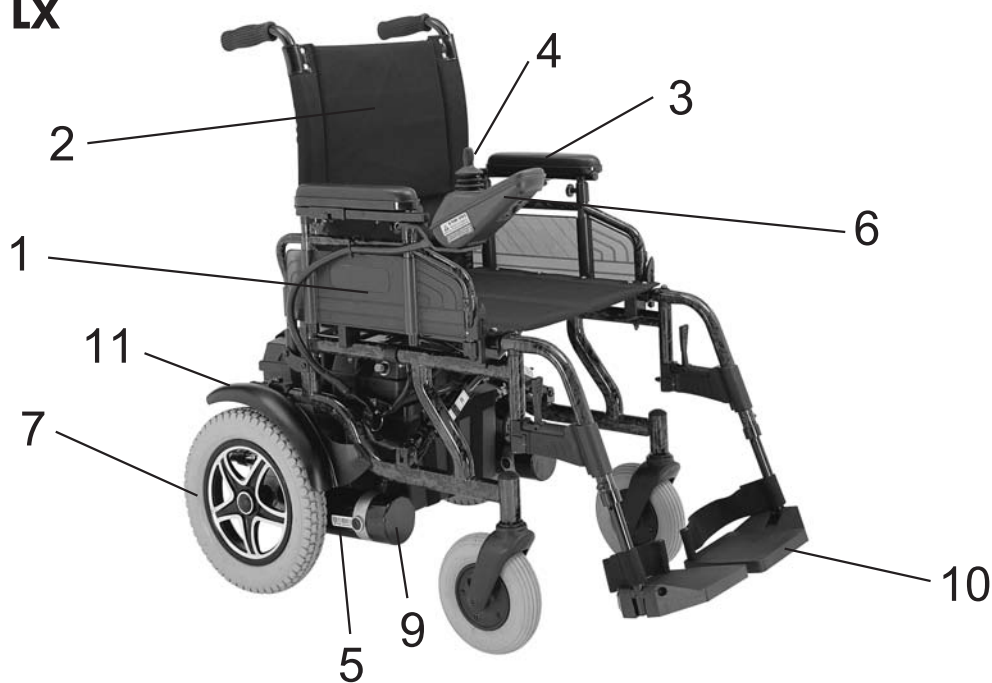

1. Flip-Up side panels
2. Removable backrest
3. Height Adjustable armrests
4. Joy-stick
5. Parking brake lever
6. Controller

7. Removable stabiliz
8. Master socket
9. Drive motor
10. Adjustable footres
11. Mudguards built - in

# Power Wheelchair User's Manual

## ■ General Specification Data

Batteries 2 x12 volt-- . . . . . 31~50 AMP-HR U1(MP-1).LX(Group) Maintenance free sealed type

Speed . . . . . 0 - 4 MPH, continuously variable

Operating range . . . . . Minimum 16 miles on level ground with 250 LB., (113.5KG) occupant.

Climbing performance . . . . . Up to 25% (1 in 4) on firm dry ground. Up to 20% (1 in 5) on loose ground (gravel, loose chips, etc.)

Brakes (on both rear wheels) . . . . . Regenerative motor brakes electromagnetic safety brakes manual parking brakes

Height of seat . . . . . 20 IN. (51 CM)

Seat width . . . . . 16-18-20-22-24 IN. (41-46-51-56-61 CM) standard 15&17 IN (38&43 CM) optional

Overall width (unfolded) . . . . . 22 - 23 - 24 - 25 - 27 IN. (55 - 57 - 60 - 63 - 68 CM)

Overall width (folded) . . . . . 14 IN. (36 CM)

Overall length . . . . . 42 IN. (106 CM)

Overall height . . . . . 40 IN. (101 CM)

Total weight (with batteries) . . . . . Approx. 117 LB. (53 KG)

Tire pressure (all wheels) . . . . . 2 - 2.5 BAR (30 - 37 PSI)

## ■ Assembly and Disassembly

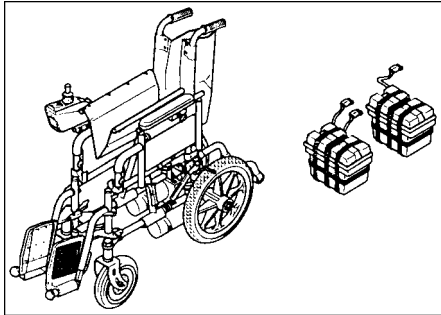

Figure 2-1

- 1). Ensure that you receive the battery boxes, footrest, and anti tipper.
- 2). Open the power chair.

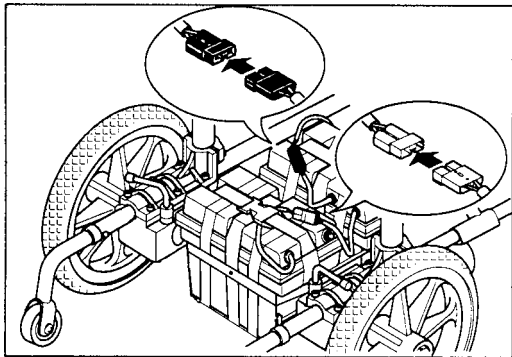

Figure 2-2

- 3). Place the basket into position (Figure 2-2).
- 4). Place batter boxes on the basket.
- 5). Plug in the power connector Black connector to black one. Gray connector to Gray one (Figure 2-2).

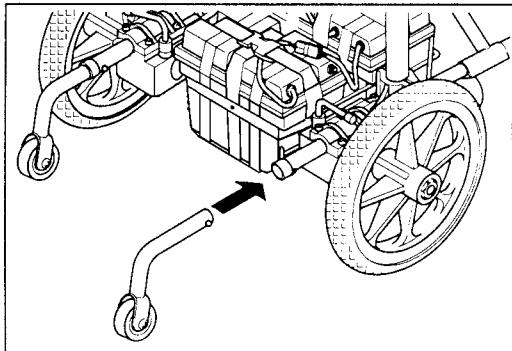

Figure 2-3

- 6). Insert the anti-tipper (Figure 2-3).

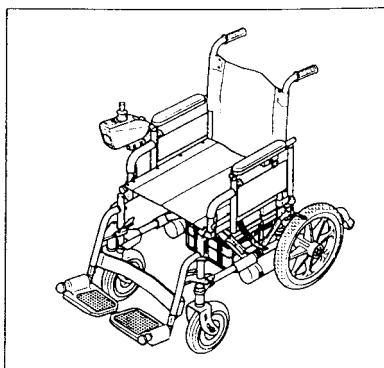

Figure 2-4

- 7). Assembled (Figure 2-4).

## Adjustment of Comfort

### ■ A. Adjustment of footrest Height

\*Caution\*

Never stand on the footrests when entering or leaving the powerchair.

Ensure that both parking brakes (Figure 1-5) are applied. fold the footrests upward and enter the powerchair from the front. When you are seated, fold the footrest plates back down to the normal position. The height of the footrests can be adjusted individually as follows:

1. Using the allenkey provided, loosen the bolt (Figure 3-1) on the footrest outer tube and slide the footrest inner tube up or down as required.
2. After adjustment, tighten the bolt.

**Note:** To enter or leave the powerchair sideways, remove the side panel / armrest. Refer to "Side Panel / Armrest Sub Assembly."

Figure 3

**MP-1**

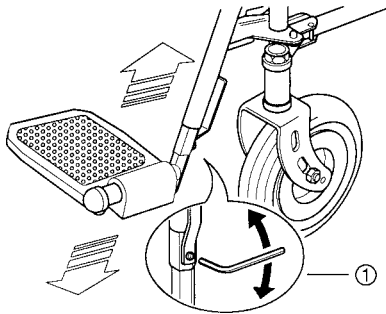

**MP-1 LX**

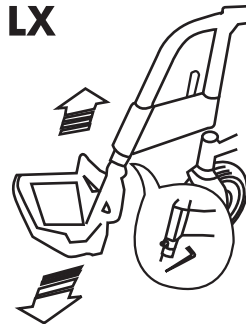

### ■ B. Adjustment of Armrest Height

To adjust the armrest height, pull out the spring-loaded plunger ① in the side panel and pull or push the armrest upward or downward until the plunger engages in the respective hole of the vertical guide rail ② to give the required armrest position.

Figure 4

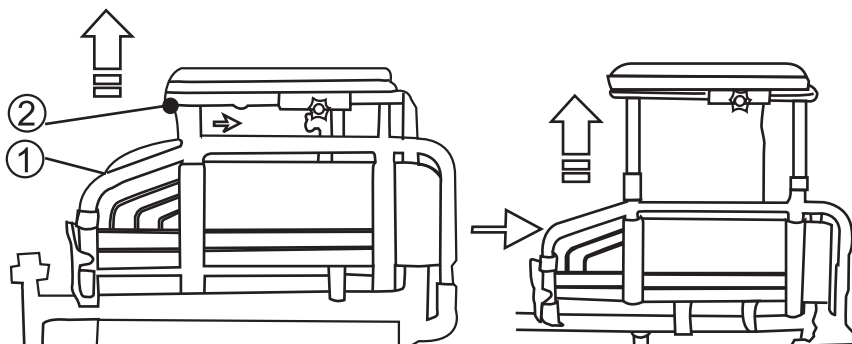

### ■ C. Adjustment of Joy-stick

Once seated and satisfied that the footrests are correctly adjusted, check to see that the controller is in a convenient position so that you can reach it easily and safely. To adjust the controller forward or rearward, loosen star knob (Figure 5-①) and retighten after adjustment.

Figure 5

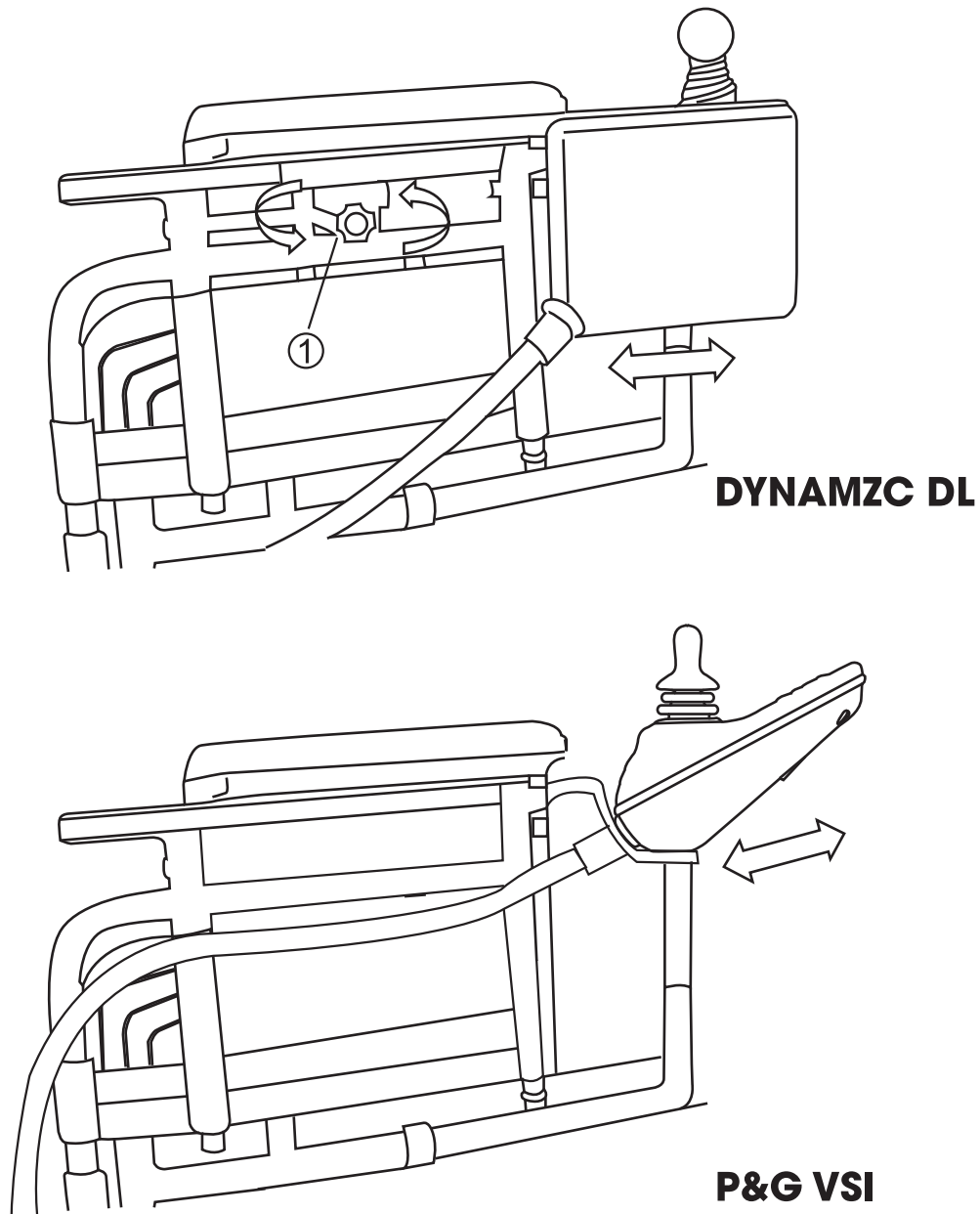

### ■ D. Climbing Curbs (Curb Rider Option Only)

The powerchair will climb low to medium high Curbs (40 MM without curb rider option) (100 MM with curb rider option installed) approach the curb head-on slowly, and shortly before the front wheels make contact with the curb, push the joy-stick fully forward for maximum power.

## Operating

### ■ A. Controls and Indicators

Figure 6

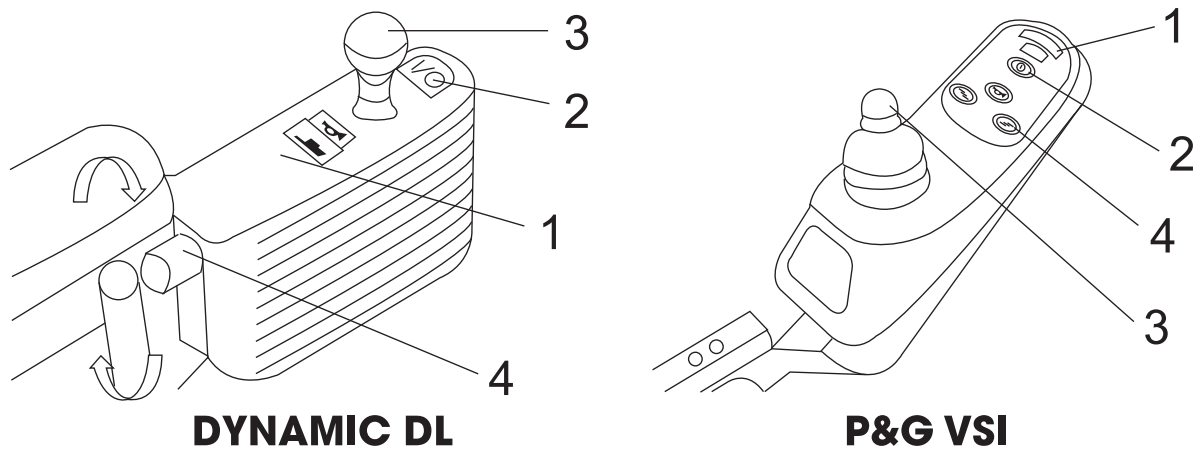

It comprises:

1. Battery gauge (fuel meter)
2. Power ON / OFF push-button
3. Joy-stick
4. Speed adjust knob

### ■ B. Let's Get Moving

Figure 7

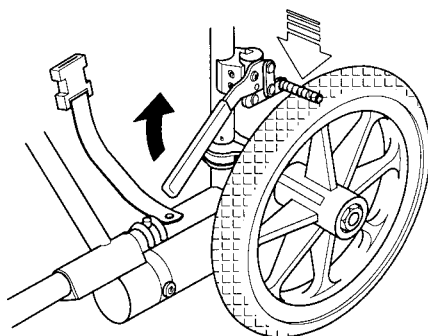

Parking Brake Levers (one on each side)

Both parking brakes are applied, you are comfortably seated.

1. Connect the master socket to the plug located on the rear face of the controller on the side of the armrest and push it firmly home.

2. For Dynamic Controller:

Turn the speed adjust knob (Figure 6 -④) to the desired maximum speed. The further you turn the knob counterclockwise, the lower the maximum speed will be when you move.

When the knob is turned to the clockwise end position, the powerchair will reach maximum speed and power. For your first drive, and in general when you move indoors, we recommend using a reduced speed setting.

3. For P&G Controller:

Press the speed / profile increase key to increase the speed or change the profile. Press the speed / profile decrease key to decrease the speed or change the profile.



## ■ C. Driving, Steering and Braking

Release the parking brakes (Figure 7). Move the joy-stick gently forward. The more you push the joy-stick forward the faster you will travel, but you will not exceed the speed limit imposed by the speed limit control, regardless of the joy-stick position.

To reverse, pull the joy-stick to the rear, beyond its center (neutral) position. The joy-stick is also your steering lever. Move it to the left and you turn left. Move it to the right and you turn right.

The powerchair is very responsive and maneuverable. It can turn within its own length. You should avoid making abrupt turns and jerky steering while you are moving at a brisk speed.

If you want to slow down, move the joy-stick toward its center position. When you want to stop or have to make an emergency brake application, simply release the joy-stick. It will automatically return to the center (neutral) position. At this moment the armature brakes of the electric motors will cut in and bring the powerchair smoothly to a standstill.

Once the powerchair is at a standstill, it is automatically locked in its parking position by the electromagnetic safety brake system. If you intend to remain parked for any length of time, or you are leaving the powerchair, apply both parking brakes. Remember to release both parking brakes before moving off again.

When climbing curbs, even with no curb riders fitted, you will find that your powerchair will smoothly overcome low to medium high curbs without the need for drastic speed variations, because the micro-computer of the electronic controller automatically compensates for any extra power required.

## Negotiating Gradients

The powerchair has a climbing power that enables you to overcome gradients of up to 25% (1 in 4).

### \*Caution\*

On loose ground (sand, gravel, grass, etc.) The maximum gradient should not exceed 20% (1 in 5).

Always approach an incline directly, not at an angle, and follow it up or down directly, not in a zig-zag movement.

### \*Caution\*

Never attempt to climb or descend an incline which has a slippery or icy surface.

While going uphill or downhill there is no need for drastic corrective joy-stick movements. The electronic controller ensures that the extra power required for climbing is automatically applied to the motors, so that the selected speed is maintained.

The same applies when you travel downhill. The armature brake and the electromagnetic safety brake give you full control over your powerchair at all times. This unique brake system enables you to descend at a constant slow speed.

You can stop at any time while you are climbing or descending. Simply release the joy-stick as on the flat. The electromagnetic safety brake will ensure that the powerchair is positively locked and secured in parking position until you are ready to continue your journey.

## ■ D. Pushing the Powerchair by Hand

Figure 8

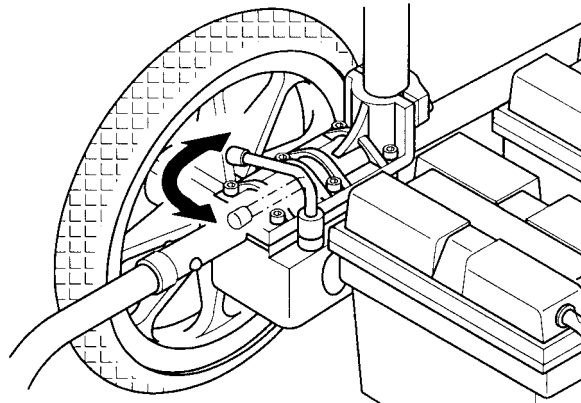

If the powerchair is to be pushed by hand, proceed as follows:

From behind the vehicle, turn the two uncoupling levers (Figure 8) of the electric motors outward to the side, so they are pointing toward the rear wheels.

Figure 9

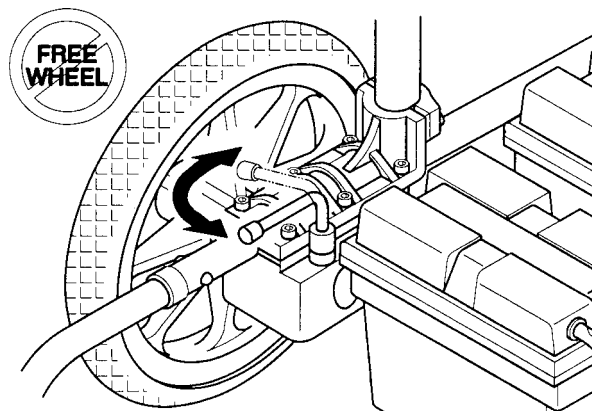

### \*Warning\*

1. Never move the uncoupling levers while the vehicle is operating with powered drive.

2. When the electric motors are disengaged the armature brakes and the electromagnetic safety brakes are out of action, so ensure the powerchair is secured with the hand-brakes when it is parked.

When normal powered operation is to be restored, retun both uncoupling levers to normal position. (Figure 9)

**Important:** The vehicle will not operate with powered drive unless both uncoupling levers are in normal position.

## ■ E. Footrest Removal Instructions

Figure 10

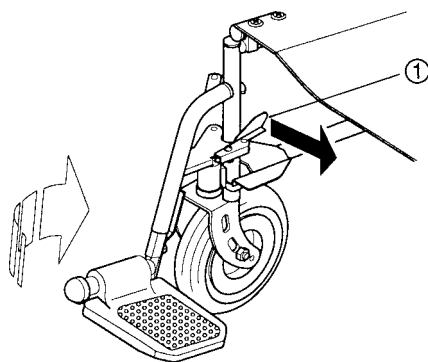

**MP-1**

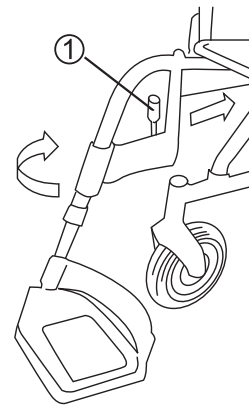

**MP-1 LX**

These parts can be removed in a simple manner without the use of any tools.

### **Footrest / (Elevating Leg Support (Optional))**

1. Push the spring loaded steel lever (Figure 10 -①) inward.
2. Swing the footrest assembly slightly outward and lift the complete footrest assembly clear of the main frame.
3. Installation is a reversal of the removal procedure.

## ■ F. Side Panel / Armrest Flip-up

Figure 11

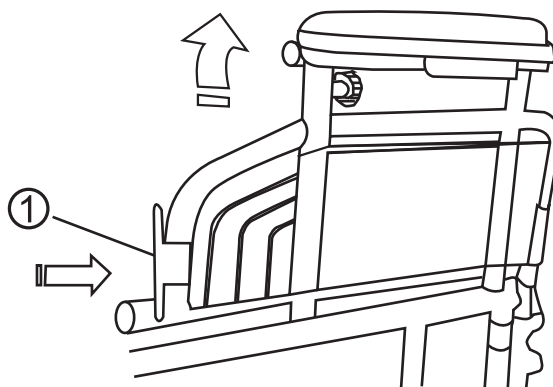

1. Simply push the arm release lever at the front of the side panel (Figure11 -①) Downward and pull the front of armrest up then swing it to the back.
2. Installation is a reversal of the removal procedure.

## ■ G. Backrest Removal Instructions

Figure 12

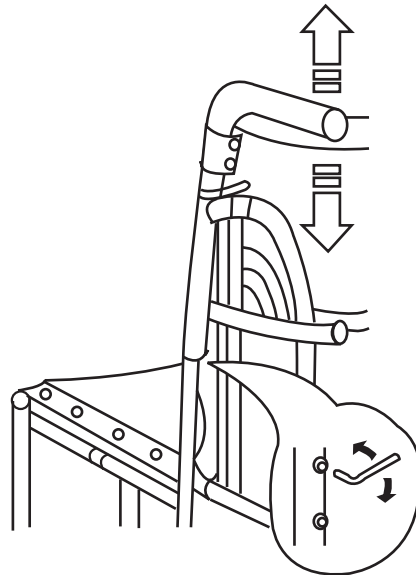

Remove the two screws and nuts from the bottom of the backrest (Figure 12) and pull the backrest upward out of the frame.

Installation is a reversal of the removal procedure.

## ■ H. Shutdown

Before you leave your powerchair, press the ON / OFF push-button. The Warning lamp and voltmeter indicator will extinguish. Fold the footrest plates upward.

Make this shutdown sequence a standard procedure and a habit. It is essential for your personal safety.

## ■ I. Getting Ready for Permanent Use

Now that you have had a good look at your brand new powerchair and taken it for a test drive in your home and around the house.

It is absolutely necessary to carry out a battery charging procedure before you start normal operation and take your powerchair on its first long-range outing. Read the next section carefully.

## ■ Batteries

The powerchair has two 12 volt, 31 AMP-HR motive-power type batteries which are accommodated in two battery boxes under the seat at the rear of the powerchair. The batteries are sealed and maintenance free.

**\*Warning\* Do not attempt to open the batteries.**

Regular monitoring of the battery charge condition and timely recharging are essential to ensure reliability and performance of your powerchair as well as long battery service life.

The intervals at which the batteries have to be recharged (hours traveled or mileage covered) depend on various factors. It is not possible to specify a generally valid fixed date. Observe the following and you will soon establish a cycle in accordance with your individual requirements and driving routine.

At full battery charge all 10 segments of the battery gauge (Figure 6 - ①), are lit continuously. With the progressive discharge of the batteries, successive segments will extinguish.

**Note:** Volt meter is only supplied on this model.

When the battery gauge has dropped to 4 scales, yellow light. Depending on age and condition of the batteries, you are then left with a limited driving range before you must recharge the batteries. (approx. 2mi.) To avoid this critical condition, we recommend charging the batteries overnight whenever you have used your powerchair. It will not only spare your unpleasant situations en route but will also prolong the battery service life.

Should you ignore this warning, while the battery, gauge is on red, and allow the batteries to become almost fully discharged, the electronic controller will automatically shut down the entire electrical system of the powerchair and bring it to a halt.

This automatic shutdown of the powerchair, accompanied by fast flashing of the ON / OFF push-button will also occur in the event of any fault in the wiring, the motors, or the controller itself.

**Note:** While climbing a steep gradient, you may find that the battery warning lamp begins to flash. This does not necessarily mean that the batteries are discharged to the critical level. Recheck the warning lamp after you reach level ground.

If during the course of the day, you have used your powerchair for more than one hour of actual traveling time, it is recommended that you charge the batteries overnight. The special-design charger will switch off automatically when the batteries are charged, so it is completely safe and does not use excess electricity regardless of the time the batteries are connected to the charger.

If your powerchair remains unused for any length of time (approximately four weeks or more), the batteries must be charged. Charge them at least once a month to maintain their charge.

## ■ Battery Charging

The batteries of your powerchair are different from ordinary car batteries. Only use the charger specifically designed for the motive-power type batteries installed.

### Charging procedure

1. Always insert the charger output plug into the charging socket on the controller. only then connect the charger input cable to an electrical outlet.
2. Follow the instructions on the front panel of the charger for its operation and the meaning of its indicators.
3. The minimum time required for charging varies and depends on battery condition and discharge level. We recommend, however, that the batteries be charged overnight.

**Note:** The specially designed charger ensures that excess power is not consumed regardless of how long it is switched on and connected to the batteries.

4. On completion of the charging cycle, first disconnect the charger input from the electrical outlet and only then disconnect the charger from the controller socket. Do not leave the charger connected to the controller when its input power is disconnected. This will cause the batteries to discharge.

For replacement of the batteries, contact your dealer.

Figure 13

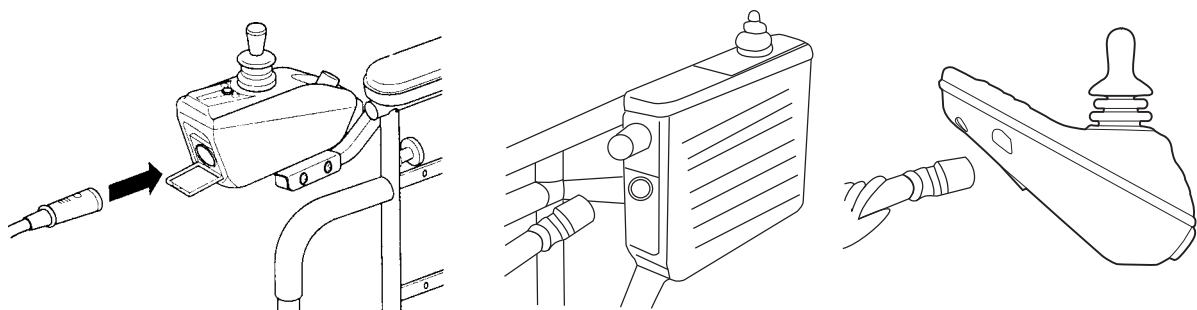



## ■ Folding the Power Wheelchair

Figure 14

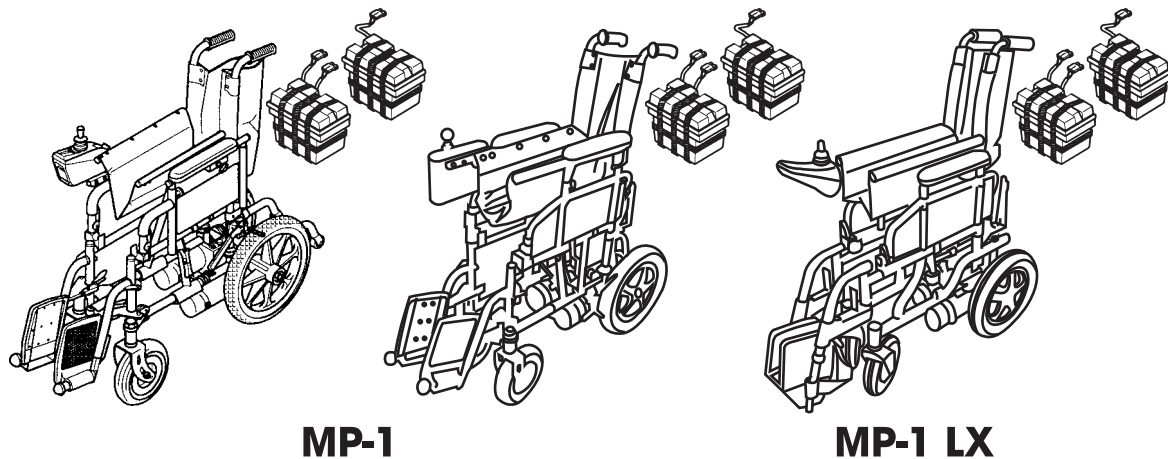

The powerchair can be folded to a neat and compact size within minutes.

1. Ensure that the master socket is disconnected.
2. Fold the two footrest plates upward.
3. Loosen the star knob for adjustment of the controller position and slide the controller back as far as it will go. Tighten the star knob.
4. Disconnect the battery cable connector from the controller cable.
5. Remove battery boxes. Note: If your power chair is fitted with the Curb Rider option, it must be removed at this time.
6. Take a firm hold of the seat support tubes on each side of the seat and pull upward. The two sides will close together to a compact stowing size.
7. If the folded powerchair is stowed or transported in a horizontal position, place it so that the side with controller is uppermost to prevent damage to the controller.

## ■ Curb Rider

### Curb Rider Installation (Optional)

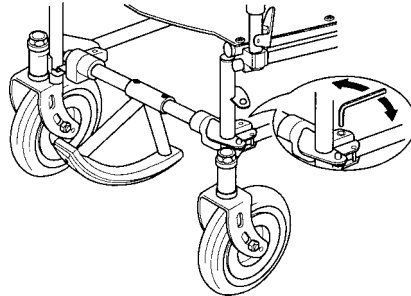

The Curb Rider is shipped completely assembled with all parts necessary to install it.

Refer to the parts list and the exploded view of the curb rider in this manual for identification of the parts.

1. Place the curb rider assembly on the lower tubular frame of the powerchair with the climber assembly (Anchor)(10.1) to the front of powerchair. Then you just need to tighten the both left and right hands of bolts (10.14)
2. Make sure the clamp (10.07) and the housing bracket (10.12) to be close each other and check the movement of the Climber (Anchor)(10.1) to be sure that the movement is smooth without any binding anywhere. Then, tightening both bolts (10.11). The Climber (anchor) should be set with 2" clearance from the ground. Once this adjustment is done, the Climber (Anchor) can rebound back the settled position whenever and wherever you move.
3. If binding occurs, please loosen both bolts (10.11). Please adjust again as above.

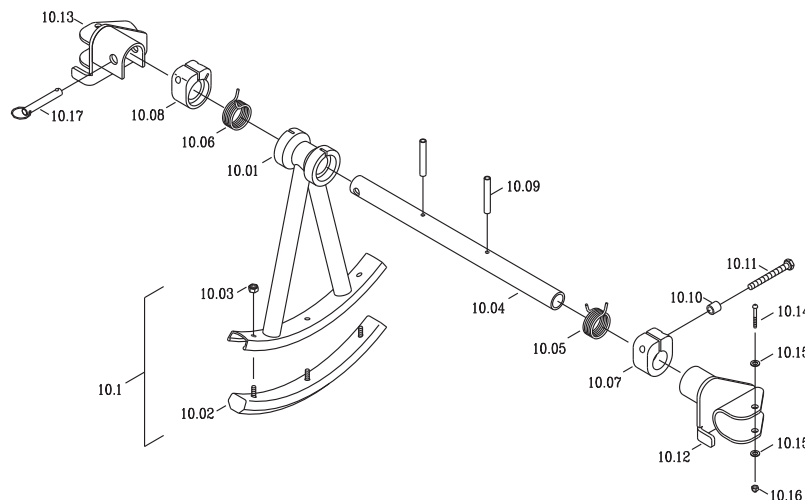

Exploded View of Curb Rider

## ■ Important Safety Information

### Foam Filled Tires

No inflation necessary

12 - 1/2" X 2 - 1/4" rear wheels

### Wheel Locks

Wheel locks should be checked regularly to ensure grip.

The purpose of the wheel locks is to hold the powerchair in place when it is stopped, not to slow it down when it is moving.

Always engage both locks before entering or exiting the powerchair.

Never stand on the footrests while entering or exiting the powerchair. Standing on the footrests could cause the powerchair to tip over.

The owner should enter or exit the powerchair only after the power is turned off.

### Turning Radius

It is very important, especially when traveling on inclines, to reduce your speed with the control joystick before making a sharp turn. Never try to turn the powerchair suddenly while traveling at full speed.

Your powerchair should not be operated on streets except when using the crosswalks. Operate your powerchair with extreme caution.

### Anti-Tip Tubes

Anti-rip tubes are standard with the powerchair. Replacements for these parts are available through your authorized dealer. Anti-tip tubes prevent the powerchair from tipping backwards. We suggest that anti-tip tubes be used on this model powerchair at all times.

### Parts

Special high strength fasteners are used on the powerchair. Replacements for these parts should be ordered through an authorized dealer.

### **\*Warnings\***

Never stand on the footrests as it may cause the powerchair to tip over.

Never lift the powerchair by the footrests. The footrests are removable and lifting the powerchair by the footrests could cause damage to the powerchair or possible injury to the owner.

Never connect the battery charger to the main supply until after you have connected it to the powerchair.

It is important to develop safe techniques before attempting to negotiate obstacles such as curbs, ramps and inclines. Never try to go up a steep incline without assistance. Avoid uneven and hilly terrain as the powerchair may tip over. Avoid grades steeper than 10% (1 foot rise in a ten foot distance) without assistance.

Control your speed carefully when traveling downhill. Slow speeds should be used when traveling on downgrades.

Do not use the ON / OFF switch to turn off the power to the power chair while it is moving. Using this switch while the power chair is still in motion causes it to come to an abrupt stop and may cause injury to the owner or damage to the power chair.

Many power wheelchair controllers have been affected by high power radio transmitters, such as CB radios and cellular telephones. If any of these devices are being used near your power chair, you should use caution in operation. If loss of control occurs, shut off your power chair immediately and leave it off until the interfering devices are no longer operating.

The user should be trained by a healthcare professional to assure safe operation of the power chair during the performance of daily activities.

### **Weight Limit**

Maximum weight limit should not exceed 250 LBS (113.4KG)

## P&G VSI Controller

The electronic controller is what you use to operate your power chair. It takes the battery voltage and sends it to the appropriate system. The electronic controller enables you to move the power chair, as well as monitor battery status, electronic controller functions, and the conditions of your electrical system. The VSI controller is an integral electronic controller. All of the electronics necessary to operate the power chair are contained in one module.

The VSI consists of:

1. Joystick
2. Keypad
3. Off-board charger / programming socket
4. Motor connectors
5. Battery connector

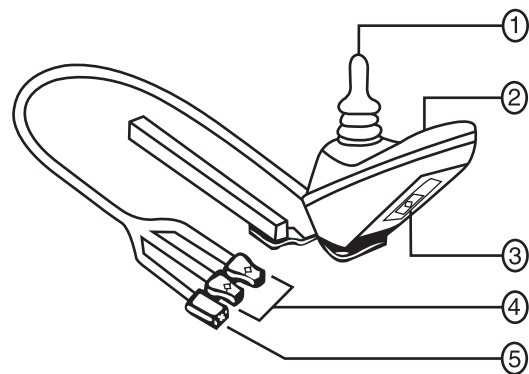

Typically, the VSI is mounted to one of the armrests and is connected to the motors and batteries.

## Joystick

The joystick controls the direction and speed of your power chair. When you move the joystick from the neutral position (center), the electromagnetic brakes release and allow your power chair to move. The further you push the joystick from its neutral position, the faster the power chair will move. When you release the joystick and allow it to return to the neutral position, you engage the electromagnetic brakes. This causes the power chair to decelerate and come to a complete stop.



**If your power chair begins to move in an unexpected manner, immediately release the joystick. Unless the joystick is damaged, this action should stop your power chair.**

## Keypad

The keypad is located on the front of the joystick. It contains keys necessary to operate your power chair.

## On / Off key

The on / off key turns the VSI on and off.

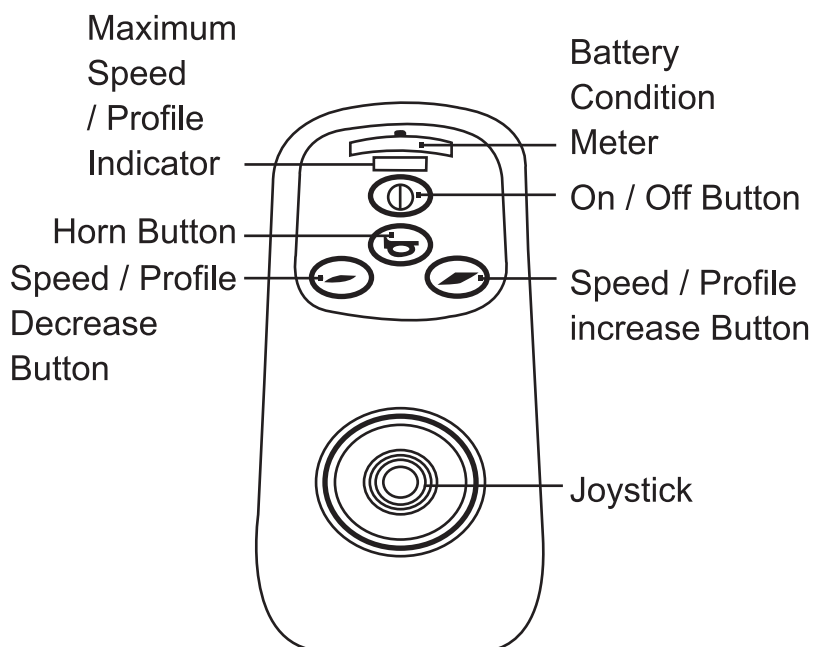

**Unless faced with an emergency situation, do not use the on / off key to stop the chair. This will cause the power chair to stop abruptly. Always turn the power off when you are stationary to prevent unexpected movement.**

## Battery Condition Meter

The battery condition meter is located on the front of the joystick. This is a 10 - segment illuminated display that indicated that the VSI is turned on and also gives the battery status, the VSI status, and the electrical system status.

**Red, yellow, and green lights lit:** Battery charge; VSI and electrical system OK.

**Red, and yellow lights lit:** Charge battery if possible; Vsi and electrical system OK.

**Red, lights only lit, or slow flash:** Charge battery as soon as possible; VSI and electrical system OK.

**Rapid flash of lights:** Indicates a fault in the VSI or the electrical system. Refer to "VSI Error Codes." Ripple up and down lights: The joystick was not in the neutral position when the controller was turned on. If you get the "ripple up and down lights", turn off the controller, allow the Joystick to return to the neutral position, then turn on the controller.

**NOTE:** If you still get the "ripple up and down lights", contact your Merits dealer.  
**NOTE:** When the batteries approach a discharged state, the first red light will begin to slowly flash, reminding you the batteries need to be charged immediately.

## Speed / Profile Keys

There are two keys that control either the speed or the profile. This depends on how your VSI was programmed. Press the speed / profile increase key to increase the speed or change the profile. Press the speed / profile decrease key to decrease the speed or change the profile.

The speed / profile setting is displayed on the maximum speed / profile indicator. If your power chair was programmed with a drive profile, contact your authorized Merits dealer to provide more information.

**NOTE:** We recommend that the first few times you operate your power chair, you set the speed to the slowest setting until you become familiar with your new power chair.

## Horn key

The horn key activated the horn.

## Off - Board Charger / Programming Socket

You may use an off - board charger to charge the power chair batteries through the 3 - pin socket located in the front of the VSI. If you use an off - board charger, the charger current should not exceed 12 amps. contact your Merits dealer for more information.

**CAUTION!** Only chargers with Neutrik NC3MX plugs should be connected to the off board charger / programming socket. See your Merits dealer for more information.

**Not:** The socket may also be used for programming the VSI. Contact your merits dealer for more information.

**NOTE:** If any of the above LEDs flash rapidly, it means either a total short circuit, a single open circuit, or a total open circuit in the associated indicator has been detected.

**CAUTION!** Failure to properly align the connectors can result in damage to the controller, the charger, and the connectors.

## Battery Connector

This connects the VSI to the power chair's battery box.

## Motor Connector

This connects the VSI to the power chair's motors and brakes.

## Thermal Rollback

The VSI controller is equipped with a thermal rollback circuit. The circuit monitors the temperature of the controller, which roughly translates to motor temperature. In the event that the VSI controller becomes excessively hot (above 140 deg. F), motor current (amperage) is reduced. For every degree above 140 deg. F, the motor current limit is reduced by 40 amps until the VSI controller reaches 158 deg. F., at which time the current output is reduced to zero. This reduces your chair's "power", which also could reduce your chair's speed, and allows the electrical components and motors to cool down. When the temperature returns to a safe level, your power chair resumes normal operation.

## VSI Error Codes

The VSI controller is designed with the user's safety as the prime consideration. It incorporates many sophisticated self-test features which search for potential problems at a rate of 100 times per second.

If the VSI detects a problem either in its own circuits or in the power chair's electrical system, it may stop the power chair, depending on the severity of the problem. The VSI is designed to maximize the user's safety under all normal conditions. The table below identifies the individual error codes. Error codes are displayed as a rapid flashing of lights. If you get one of these error codes, please contact your Merits dealer.

Flashing Lights	Diagnosis / Solution
1	The battery needs charging, or there is a bad connection to the battery. Check the connections to the battery. If the connections are good, try changing the battery.
2	The left motor has a bad connection. Check the motor connection.
3	The left motor has a short circuit to a battery connection. Contact your Merits dealer.
4	The right motor has a bad connection. Check the motor connection.
5	The right motor has a short circuit to a battery connection. Contact your Merits dealer.
6	The power chair is being inhibited by the battery charger. Unplug the battery charger.
7	A joystick fault is indicated. Make sure that the joystick is in the neutral (center) position before turning on the controller.
8	A controller fault is indicated, make sure that all connections are secure.
9	The parking brakes have a bad connection. Check the parking brake and motor connections, make sure the controller system connections are secure.
10	An excessive voltage has been applied to the controller system. This is usually caused by a poor battery connection. Check the battery connections.



## Dynamic DL Controller

The Dynamic DL controller joystick has on knob that combines both speed and response functions. See figure 15 When you increase the speed, you decrease the sensitivity. When you decrease the speed, you increase the sensitivity.

**NOTE:** We recommend that you turn the speed and response adjustment knob completely counterclockwise (to the slowest setting) the first few times you operate your power chair to allow yourself to become familiar with your new power chair.

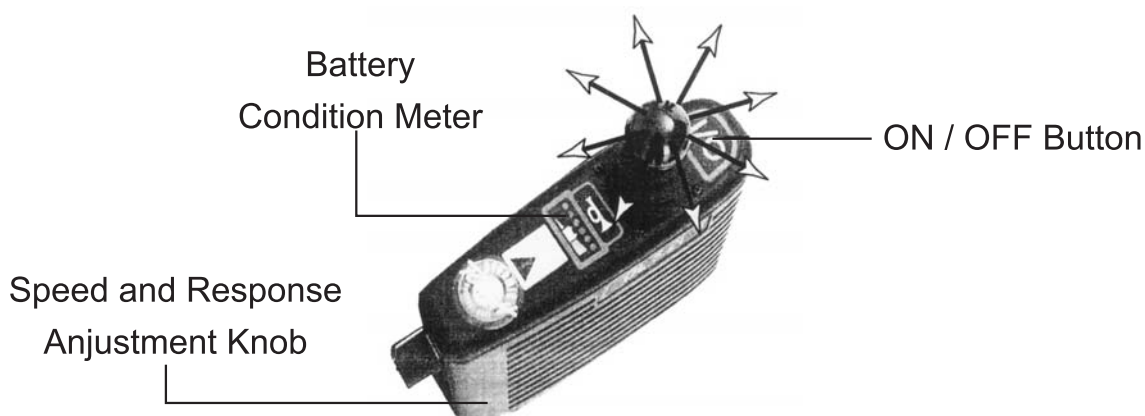

Figure 15. Dynamic DL Controller

## Battery Condition Meter

The battery condition meter is located immediately behind the joystick. This enables you to monitor battery charge. The battery condition meter indicates the approximate amount of battery charge left. See figure 18.

- Red, yellow, and green LEDs indicate that the batteries are fully charged.
- Red and yellow LEDs indicate that you should charge the batteries if possible.
- Red LEDs indicate that you should charge the batteries as soon as possible, because low battery voltage may cause your power chair become inoperative.

**NOTE:** When the batteries begin to approach a discharged state, the first red LED will begin to slowly flash, reminding you that the batteries need to be charged immediately!

## Error Codes

In addition to indicating the current state of battery charge, the battery condition meter can also indicate possible problems with your power chair. If the battery condition meter is flashing rapidly, the controller may be indicating a fault.

The following is a list of the possible errors signified by the rapidly flashing meter.

Flashing Lights	Diagnosis	Solution
1	Low battery voltage fault	Check Batteries / Battery Wiring
2	High battery voltage fault	Check Batteries
3	Left motor (or connection) fault	Check Left Motor Wiring
4	Right motor (or connection) fault	Check Right Motor Wiring
5	Left or right park brake (or connection) fault	Check Motor / Brake Wirin
6	Controller fault	See Your Authorized Merits Provider
7	Motor stalled or joystick out of neutral time out	Reset the Power On / Off Button

**NOTE:** You must turn the controller off and then on again to reset the controller, even if the source of the fault is removed / corrected.

In the event of a fault, the flashing battery condition meter displays diagnostic indications. Faults are encoded as follows: one (for a low battery voltage fault) to seven (for a motor stalled or joystick out of neutral time out fault) and are displayed by flashing all LEDs the number of times prescribed by the fault code. The flash sequence (one to seven) is followed by a long off period (2 seconds). If more than one fault exists, then the fault having the highest priority is indicated. The controller must be turned off and then on again even if the source of the fault is removed. If you cannot resolve the problem, contact your authorized Merits provider.

## **Thermal Rollback**

The power chair controller is equipped with a thermal rollback circuit. This circuit monitors the temperature of the motors and the controller. In the event that the motors or the controller become excessively hot (above 122°F), the controller reduces the motor voltage. For every degree above 122°F, the controller reduces the voltage by 5 volts. This reduces your power chair speed and allows the electrical components to cool down. When the temperature returns to a safe level, your power chair resumes its normal speed capability.

## **Battery Boxes**

On the top right side of the rear battery box, you will see the reset button of a circuit breaker. This button must always be pressed in, otherwise the powerchair will not operate. \*Refer to the Troubleshooting Guide\* Also on the battery boxes are cables with connectors for connecting the batteries together and to connect batteries to the controller box. To remove the battery boxes, (when you want to fold the powerchair) you must first disconnect these connectors from the battery boxes.

## ■ Maintenance

There are no specific maintenance requirements for the joy-stick and the controller, but the service life of the equipment will be extended if you observe the following:

The joy-stick box and the controller are splash proof but should be protected from excessive spillage of liquid. Do not expose to direct heat (from an electric heater, for example). Check that the rubber boot on the joy-stick and switch cover are in good condition and show no holes or cracks.

### Wheels - Removal / Installation

#### A. Rear Wheel

1. Ensure that the freewheel lever of the motor drive is engaged. (Figure 10)
2. Support or jack up the powerchair under the frame side-member.
3. Unscrew the hexagon nut and remove, together with the washer.
4. Withdraw the rear wheel from the drive axle.

Installation is a reversal of the removal procedure. Check that the threads of the hexagon nut are undamaged and clean. If necessary, wipe with a clean dry cloth. Do not use any sharp tools to clean the threads. Do not forget to slide the washer over the nut before it is screwed in. Tighten the nut firmly.

#### B. Front Wheel

1. Support or jack up the powerchair under the frame side-member.
2. Using the wrench provided, remove the axle bolt.
3. Slide the front wheel out of the fork.

Installation is a reversal of the removal procedure.

#### C. Pneumatic Tire Inflation (Hand Pump for Emergency)

1. Take out the connection adaptor from air pump.
2. Insert the adaptor to the pump and the valve of tire.
3. Start to inflate tire to your desired (30 ~ 37 psi) air pressure.

Figure 16

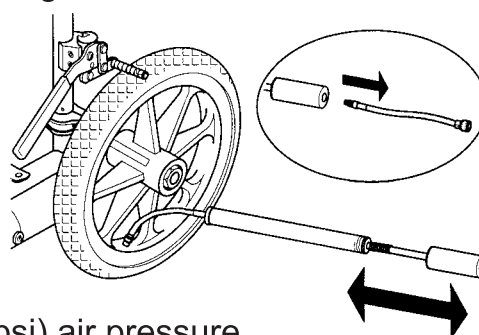

## ■ Troubleshooting Guide

Nature of Fault	Problem Cause	Action
1. Powerchair will not move, power on lamp doesn't light up.	<ul style="list-style-type: none"> <li>a) Master plug not inserted</li> <li>b) ON / OFF push-button in off position</li> <li>c) Batteries discharged to low level</li> <li>d) Loose plug connection at controller or battery</li> </ul>	<ul style="list-style-type: none"> <li>a) Insert master plug</li> <li>b) Press in</li> <li>c) Re-charge the batteries</li> <li>d) Press plugs firmly into sockets</li> </ul>
2. Powerchair will not move, power on lamp lights up.	<ul style="list-style-type: none"> <li>a) Drive motor not engaged</li> <li>b) Fault in controller electronics</li> </ul>	<ul style="list-style-type: none"> <li>a) Reset uncoupling lever(s)</li> <li>b) Consult dealer</li> </ul>

**\*Important\***

In all cases of an electrical fault, check that the circuit breaker (located on the rear battery box) is pressed in. If it has been tripped it must be pressed. If the reset button comes out again, even after the suspected cause of the fault has been corrected, consult your dealer.

We wish you a safe and comfortable riding experience!

