

# Owner's Manual

## SAFETY GUIDELINES

The symbols below are used throughout this owner's manual and on the product to identify warnings and important information. It is very important for you to read them and understand them completely.



**WARNING!** Indicates a potentially hazardous condition/situation. Failure to follow designated procedures can cause either personal injury, component damage, or malfunction. On the product, this icon is represented as a black symbol on a yellow triangle with a black border.



**MANDATORY!** These actions should be performed as specified. Failure to perform mandatory actions can cause personal injury and/or equipment damage. On the product, this icon is represented as a white symbol on a blue dot with a white border.



**PROHIBITED!** These actions are prohibited. These actions should not be performed at any time or in any circumstances. Performing a prohibited action can cause personal injury and/or equipment damage. On the product, this icon is represented as a black symbol with a red circle and red slash.



**CALIFORNIA PROPOSITION 65 WARNING!** This product may contain substances which are known to the state of California to cause cancer and birth defects or other reproductive harm. For more information, go to [www.P65Warnings.ca.gov](http://www.P65Warnings.ca.gov).

### INTENDED USE

The intended use of the this device is that of a device with motorized positioning control that is intended for medical purposes and that can be adjusted to various positions. The device is used to provide stability for patients and to alter postural positions. This device will provide lift assistance for people who have difficulty rising from a seated position to a standing position.

### REGARDING DEVICES FOR PRESCRIPTION USE



**CAUTION!** Federal law restricts this device to sale by or on the order of a physician or other certified personnel licensed by the law of the State (US only) or region in which this personnel practices to use or order the use of this device.

**Please fill out the following information for quick reference:**

Provider: \_\_\_\_\_

Address: \_\_\_\_\_

Phone Number: \_\_\_\_\_

Purchase Date: \_\_\_\_\_ Serial Number: \_\_\_\_\_

*NOTE: This owner's manual is compiled from the latest specifications and product information available at the time of publication. We reserve the right to make changes as they become necessary. Any changes to our products may cause slight variations between the illustrations and explanations in this manual and the product you have purchased. The latest/current version of this manual is available on our website.*

*NOTE: This product is compliant with WEEE, RoHS, and REACH directives and requirements.*

*NOTE: The chair and its components are not made with natural rubber latex. Consult with the manufacturer regarding any after-market accessories*



**I. INTRODUCTION ..... 4**

**II. SAFETY ..... 5**

**III. YOUR CHAIR..... 8**

**IV. ASSEMBLY/DISASSEMBLY ..... 11**

**V. OPERATION ..... 16**

**VI. BASIC TROUBLESHOOTING..... 18**

**VII. CARE AND MAINTENANCE ..... 20**

## I. INTRODUCTION

---

### SAFETY

The product you have purchased combines state-of-the-art components with **safety**, comfort, and styling in mind. **Read** and **follow** all instructions, warnings, and notes in this manual and all other accompanying literature before attempting to operate this product for the first time. If there is any information in this manual which you do not understand, or if you require additional assistance for setup or operation, please contact your authorized provider. **Failure to follow the instructions, warnings, and notes in this manual and those located on your product can result in personal injury or product damage and will void the product warranty.**

***NOTE: If you ever lose or misplace your copy of this manual, contact us and we will be glad to send you a new one immediately.***

### PURCHASER'S AGREEMENT

By accepting delivery of this product, you promise that you will not change, alter, or modify this product or remove or render inoperable or unsafe any guards, shields, or other safety features of this product; fail, refuse, or neglect to install any retrofit kits from time to time provided to enhance or preserve the safe use of this product.

### SHIPPING AND DELIVERY

Before using your chair, make sure your delivery is complete as some components may be individually packaged. If you do not receive a complete delivery, please contact your authorized provider immediately. Where damage has occurred during transport, either to the packaging or content, please contact the delivery company responsible.

### MOTOR VEHICLE TRANSPORT

If you will be transporting your chair in a motor vehicle, individual components (external transformer, etc.) should be secured against slipping. The chair itself must also be secured against slipping (a possible hazard during vehicle braking).

**PRODUCT SAFETY SYMBOLS**

The symbols below represent labels used on the product to identify warnings, mandatory actions, and prohibited actions. It is very important for you to read and understand these symbols completely. Do not remove these labels from your product. Please note that not all of the symbols may be used on your chair model.



Pinch/Crush Points Hazard! Do not place objects or appendages in the path of moving parts.



Electrical Hazard



This product has been tested and complies to IEC 60601-1-2.



Read and follow the information in the owner's manual.



Maximum weight capacity



Do not connect an extension cord to the AC/DC converter or the battery charger.



Removal of grounding prong can create electrical hazard. If necessary, properly install an approved 3-pronged adapter to an electrical outlet having 2-pronged plug access.



Do not connect the heat and massage hand control directly to the motor. Connect the hand control directly to the junction box to prevent equipment damage.



Do not place objects under chair. Make sure area is clear of obstructions, including pets and small children, during operation.



Do not place objects under the footrest when chair is in fully reclined position. Make sure area is clear of obstructions, including pets and small children, during operation.



Do not cover or place the external transformer under the chair. Keep in an open, well-ventilated area free from foreign material and away from possible pinch points.



Class II Equipment



Indoor Use Only. Avoid exposure to rain, snow, ice, salt, or standing water. Maintain and store in a clean and dry environment

## II. SAFETY

---



Battery Door Location (This does not apply to chairs with lithium-ion battery pack.)



TYPE B

Degree of protection against electric shock



Properly dispose of all electronic components, including the external transformer, hand control, batteries, actuator motors, and wiring. Contact your authorized Provider for more information.

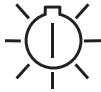

Green LED indicates power to the unit is on. Not applicable to all models.

Your chair is a state-of-the-art life-enhancement device designed to increase comfort. An extensive variety of products are provided to best fit your individual needs. Please be aware that the final selection and purchasing decision regarding the type of chair to be used is the responsibility of you, the chair user, if capable of making such a decision, and/or your healthcare professional (i.e., medical doctor, physical therapist, etc.).



**MANDATORY!** Read and follow the information provided in this owner's manual before attempting to operate your chair for the first time.

There are certain situations, including some medical conditions, where you will need to practice operating the chair in the presence of a trained attendant. A trained attendant can be defined as a family member or healthcare professional specially trained in assisting you with performing various daily living activities while safely operating a chair.

Below are some precautions, tips, and other safety considerations that will help you become accustomed to operating the chair in a safe manner.

### Modifications

You should not modify, add, remove, or disable any feature, part, or function of your chair. Unauthorized modifications may lead to personal injury and/or product damage and may also void your product's warranty.

*NOTE: Use only manufacturer parts for all repairs and replacements.*

### Weight Limitations

Your chair is rated for a maximum weight capacity. Please refer to the specifications table for this limit.



**MANDATORY!** Stay within the specified weight capacity of your chair. Your provider will not be held responsible for injuries and/or product damage resulting from failure to observe weight limitations.

### Pinch/Crush Hazards

The scissor and lift mechanisms are labeled as pinch/crush point hazards on your chair. Keep clear of these areas and make sure the path of motion is unobstructed. See **figure 3.1** for pinch/crush point locations.



WARNING! Do not place objects or appendages in the path of moving parts.

### Degree of Protection/Mode of Operation

- Class II equipment/Type B protection against electric shock
- Mode of operation—Maximum Duty Cycle: 2 min. ON/18 min. OFF

### Storage and Operation Temperatures

- Transportation or storage: -40°F/-40°C to 149°F/65°C
- Operation: 50°F/10°C to 104°F/40°C

### Electromagnetic and Radio Frequency Interference (EMI/RFI)



WARNING! Laboratory tests have shown that electromagnetic and radio frequency waves can have an adverse effect on the performance of electrically-powered devices, such as chairs.

Electromagnetic and Radio Frequency Interference can come from sources such as cellular phones, mobile two-way radios (such as walkie-talkies), radio stations, TV stations, amateur radio (HAM) transmitters, wireless computer links, microwave signals, paging transmitters, and medium-range mobile transceivers used by emergency vehicles. In some cases, these waves can cause unintended movement or damage to the control system of electrically-powered devices. The chair user can help prevent electromagnetic interference by maintaining a minimum distance between portable and mobile RF communications equipment. It is recommended that at least 9 feet (3 meters) of distance be maintained between the chair and any handheld equipment emitting 10 W or more of output power. Refer to the manufacturer's literature for the handheld device to determine the maximum output of that device.

Every electrically-powered device has an immunity (or resistance) to EMI. The higher the immunity level, the greater the protection against EMI. Per EMC standards, this product has passed immunity testing and is rated as a Group 1, Class B product, meaning the chair uses RF energy only for its internal function. Therefore, its RF emissions are very low and are not likely to cause any interference in nearby electronic equipment, making the chair suitable for use in all establishments, including domestic establishments and hospitals.



WARNING! Be aware that cell phones, two-way radios, laptops, and other types of radio transmitters may cause unintended movement of your electrically-powered device due to EMI. Exercise caution when using any of these items while operating your chair.



WARNING! The addition of accessories or components to the chair can increase the susceptibility of the chair to EMI. Do not modify your chair in any way not authorized by your provider.

WARNING! Your chair itself can disturb the performance of other electrical devices located nearby, such as alarm systems.

*NOTE: If unintended motion occurs, discontinue use of the chair. Contact your provider to report the incident.*

### III. YOUR CHAIR

#### BODY COMPONENTS

Chairs are equipped with several frame and electrical components. Typically, frame (or body) components include a removable back pad\*, removable chaise pad\*, footrest, leg levelers, a lift mechanism, and scissor mechanisms. The electrical components include the external transformer, hand control, and batteries‡ (not included). Refer to **figure 3.1** and note that the illustrations and options listed may not reflect the type of chair that you own.

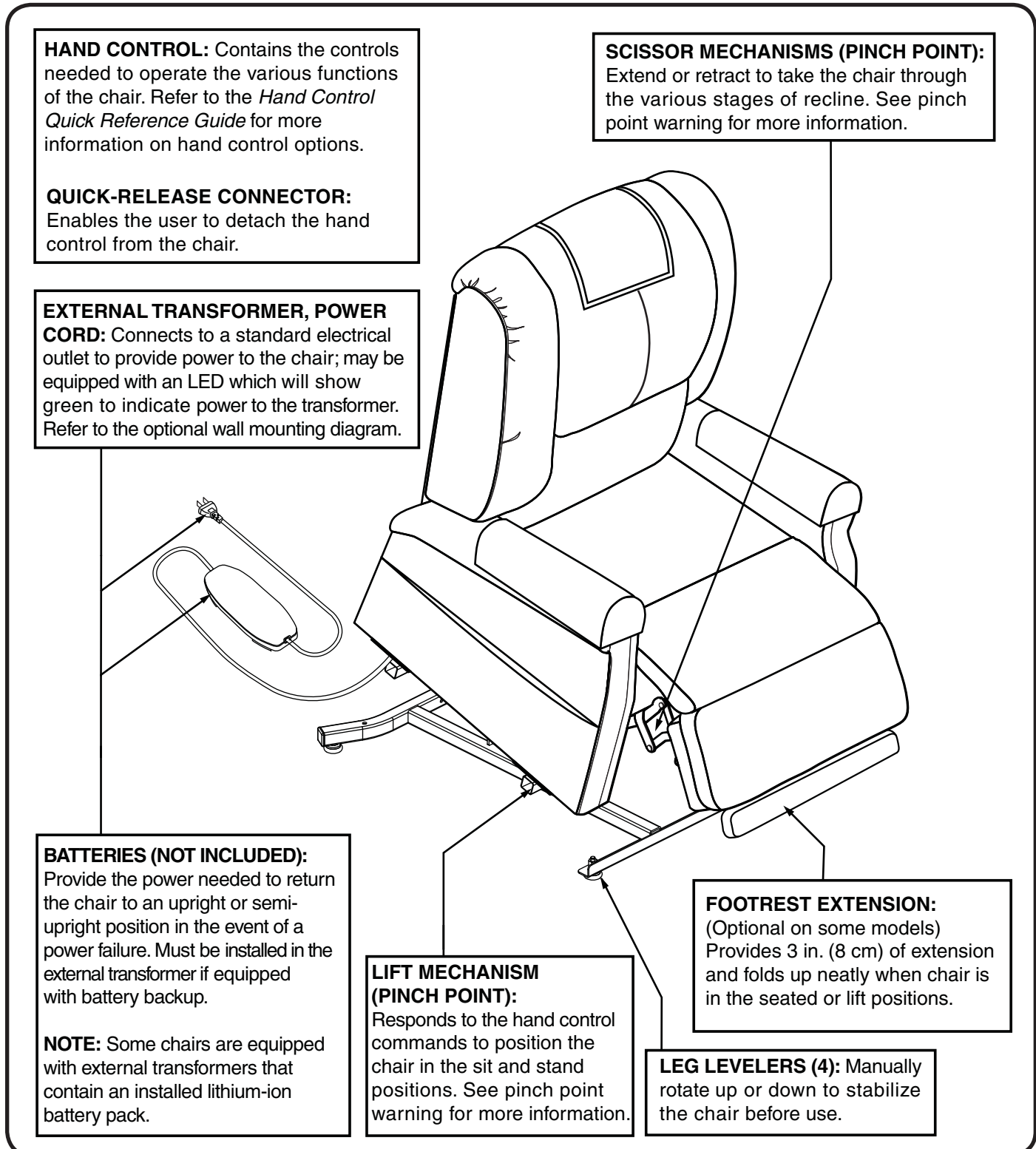

Figure 3.1 Chair Main Components



**Removable Back Pad:** Attaches to the chair with reusable fasteners to enable the use of the bed option on some models and to make servicing the chair more convenient.

**Removable Chaise Pad:** Attaches to the chair with reusable fasteners to make servicing the chair more convenient.

*\*NOTE: The chair must be in the recline position in order to remove or attach the back pad, chaise pad, or bed option mattress (if equipped). If the chair is equipped with heat and massage options, you must also disconnect the heat and massage connections before removing the back pad and/or chaise pad.*

*\*NOTE: The bed option consists of a mattress, bedsheet, strap, and storage bag. After removing the mattress, it is recommended that you store it in the bag provided.*

*†NOTE: 9V batteries will provide power for only a short period of time after power is removed from the system, so it is important to act quickly in the event of a power failure. Press and hold the UP button (switch) on the hand control as soon as possible. Maintain a steady pressure on the button (switch) to avoid excessive draw from the battery and achieve the most amount of lift. Keep in mind that the amount of life the batteries will be able to provide is affected by user weight and battery condition.*

WARNING! Pinch/Crush Points Hazard! Be aware that the lift mechanism and scissor mechanisms are pinch points on the chair. Keep the following items and similar objects clear of these points when operating the chair:



- appendages
- small children
- pets
- wires
- oxygen tubes, oxygen tanks, and portable ventilators
- loose items, including but not limited to clothing and blankets
- electrical power cords

#### Electrical Components

Your chair is equipped with a low voltage DC electrical system that reduces the standard household alternating current of 100V AC - 240V AC to direct current (24/39V DC). The electrical components include the external transformer, batteries (not included), and hand control. Keep these areas free from moisture at all times.



WARNING! Keep all electrical components free from moisture at all times to prevent shock and/or electrical hazard.

**Batteries:** Provide the power needed to return the chair to an upright or semi-upright position in the event of a power failure. For those models equipped with a battery backup system, the batteries (not included) must be installed into the external transformer. See IV. "Assembly/Disassembly."

### III. YOUR CHAIR

---

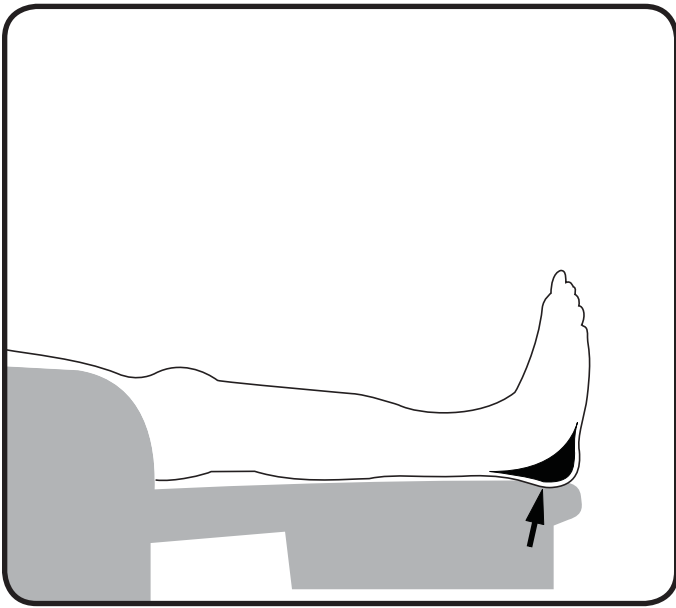

Figure 3.2 Footrest

- Chairs are designed so that your feet hang over the end. If your heels were on the footrest, it would put pressure on your heels and leg muscles, and would become uncomfortable after a short period of time.

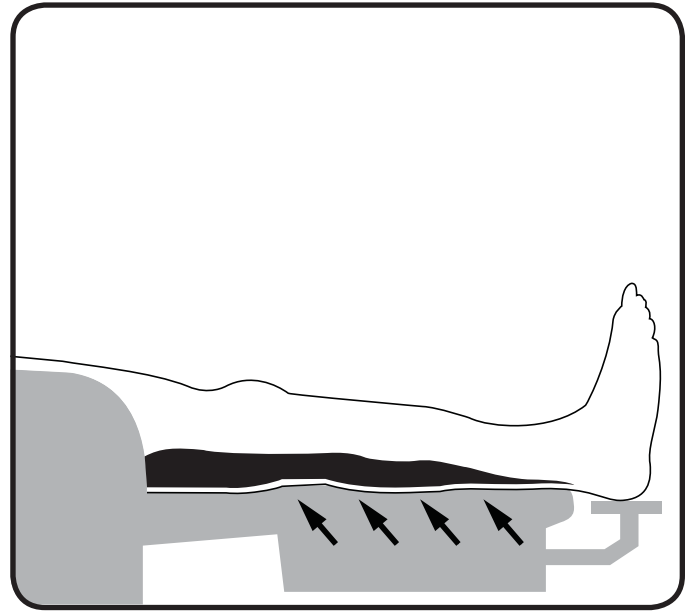

Figure 3.3 Footrest extension

- However, when your heels hang over the edge of the footrest, it puts the weight of your legs on the backs of your calves. This distributes the weight evenly to larger portions of your legs, and you are able to sit for long periods of time without any discomfort. The footrest extension is designed to help support your feet and to sit below the footrest to go with the natural curve of the foot.

*NOTE: Please note that the footrest extension may not be level with the footrest.*

Your chair may require some assembly before initial use. It may also require disassembly to make servicing the chair more convenient. If your chair is a Knock-Down (KD) model, follow the instructions in “Chair Back Assembly”

**CHAIR BACK ASSEMBLY**

*NOTE: If your chair is an Infinite model, refer to the assembly instructions provided with the chair. For the 2-position model, the KD sleeves are located on the inside as shown in figure 4.1.*

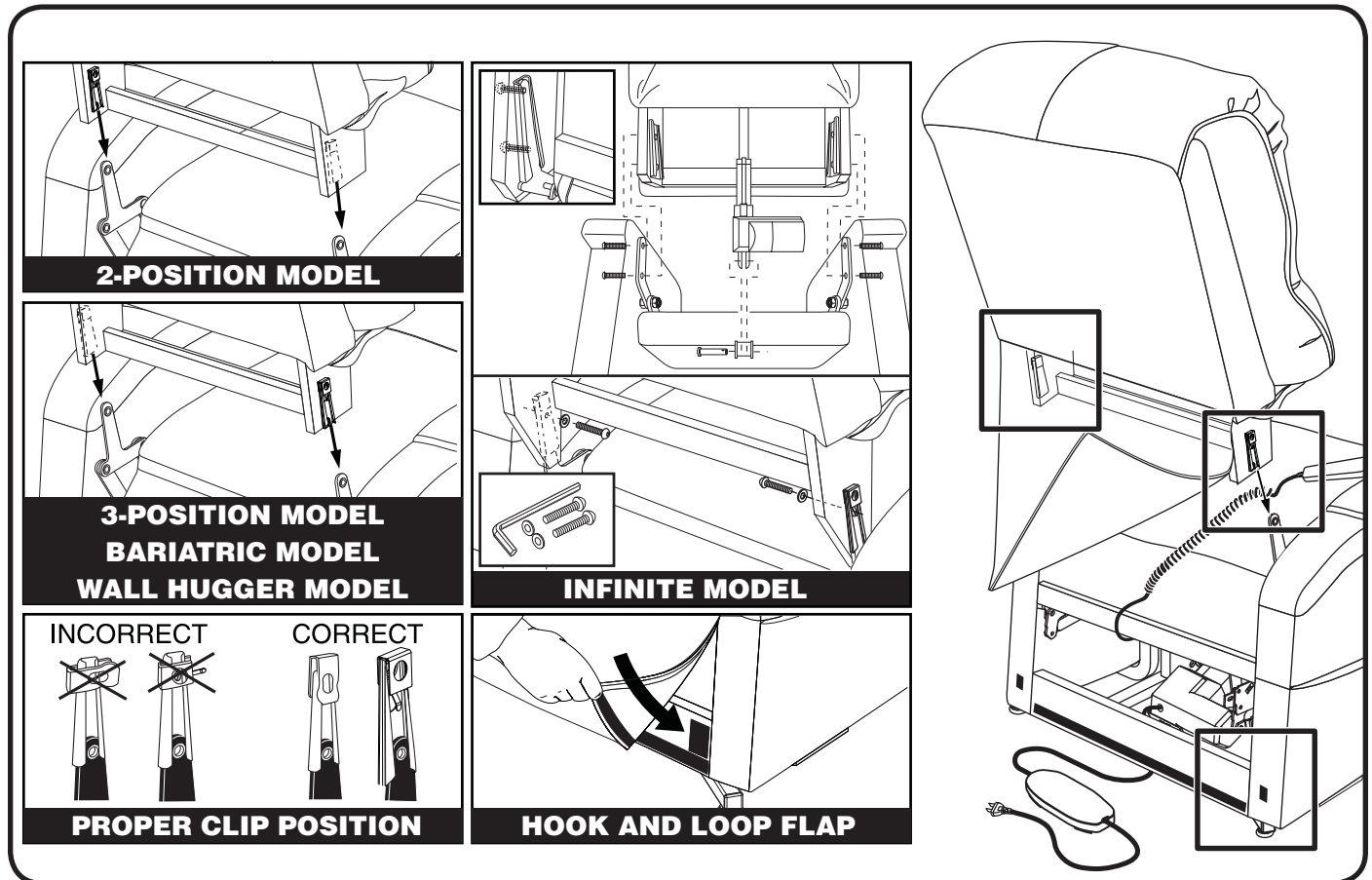

**Figure 4.1 Chair Assembly**

1. Check that the locking clip on the back of the chair is in the vertical position. Reposition if necessary.
2. Drape the hand control and cable over the chair base, then slide the back onto the base. Ensure the hand control cable is routed through the rear of the chair.

*NOTE: Depending on chair width, you may need to slide on one side of the back at a time. If this is the case, level the chair-back before pressing down to lock into position.*

3. Push firmly on the top of the back to lock into position. You must hear a click from each side of the chair to ensure the back is locked in properly.

## IV. ASSEMBLY/DISASSEMBLY

*NOTE: Pull up on the chair-back to ensure that it is locked in place.*

*NOTE: See figure 4.2 for additional instructions regarding models equipped with bed option.*

4. Connect the hand control harness to the chair and heat/massage harnesses (if equipped) to the chair (fig 4.3).



**WARNING!** Do not connect the push-button or heat/massage hand control directly to the motor. Connect the hand control directly to the junction box to prevent equipment damage.

5. Attach the chair-back to the hook and loop flaps on the bottom of the chair base.

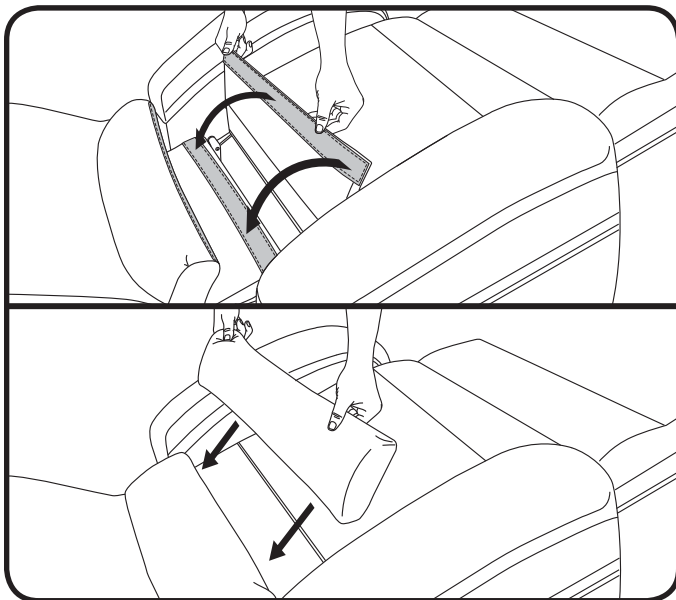

**Figure 4.2 Bed Option Additional Assembly**

- For chairs with a bed option, after attaching the back per the KD instructions, fully recline the chair and place the base flap over the gap between the seat and back. Using the reusable fasteners, secure the base flap to the chair and then secure the bottom-most pillow to the base flap.
- Place the bolster pillow over the covered gap, slightly wedging it between the back and seat, and return the chair to the seated position.

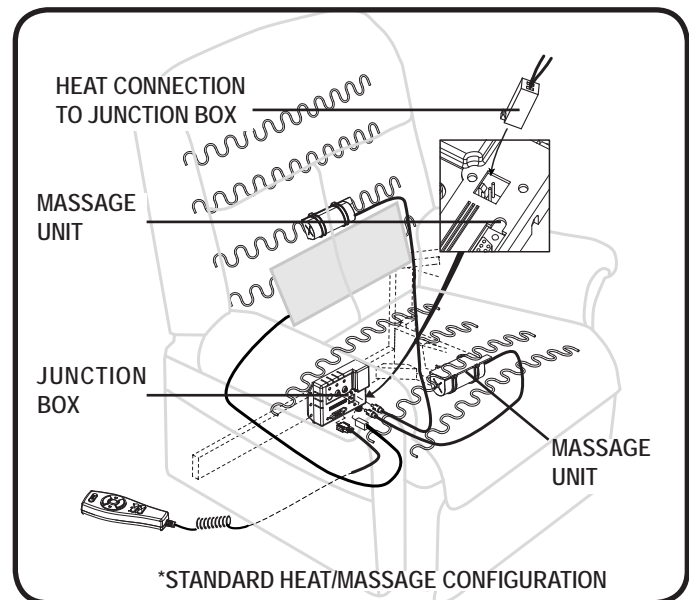

**Figure 4.3 Harness Connections**

- For units equipped with the heat and massage option, connect the heat and massage harnesses to the chair.
- The heat pad(s) and massage units have been factory installed on your chair. You should only need to connect the harnesses to the chair. If you find any further assembly is required with this system, contact your authorized provider immediately.



**WARNING!** Be aware that the average temperature of the heating pad ranges between 106°F - 118°F (41°C - 48°C) and can be affected by the ambient temperature of the room and clothing worn by the user. Your provider recommends that the heat units not be used for more than 20 minutes at a time as prolonged exposure may have an adverse effect on sensitive skin. However, you should consult the physician about how often you should use the heat and massage options on your chair.

**WARNING!** Exercise extreme caution when using heat units if you have difficulty sensing heat.

## CHAIR PLACEMENT

Your chair should be placed near a standard electrical outlet on dry, level ground where there is ample room to allow for proper operation. We recommend that you have the assistance of an attendant when positioning the chair to avoid the possibility of injury when lifting.

### **Follow these steps to position the chair in a safe manner:**

1. Place the back of the chair 30 in. (76 cm) from the nearest obstruction while the chair is in the seated position. This measurement may vary depending on model.
2. Adjust the leg levelers to stabilize the chair (**fig. 3.1**).
3. Install the batteries into the external transformer if applicable. Refer to “Battery Installation” for more information.
4. Position the external transformer on the floor in an open, well-ventilated area where it will not be an obstruction or, if equipped, use the optional wall mount.
5. Position the low voltage connection cable where it will not be pinched between the frame and the lift mechanism.
6. Connect the low voltage connection cable to the external transformer if it is not already connected.
7. Plug the power cord directly into the electrical outlet. **Do not use an extension cord!**

*NOTE: If you discover a problem at any point during the setup and positioning of your chair, stop and contact your authorized provider immediately. To avoid personal injury and/or product damage, do not plug the unit into the electrical outlet until the problem is corrected and do not attempt to fix electrical problems by yourself.*

## IV. ASSEMBLY/DISASSEMBLY

### BACK-UP BATTERY INSTALLATION

*NOTE: Your chair is equipped with either a 9V or lithium-ion battery pack battery back-up system. Refer to the section that corresponds to your battery back up system.*

#### 9V Battery Back-Up System

Your chair may be equipped with a battery backup system that will activate during a power failure. The backup system is powered by two 9V batteries (not included) that need to be installed into the external transformer.

##### Follow these steps to install the 9V batteries:

1. Unplug the external transformer power cord from the electrical outlet.
2. Open the marked battery door on the external transformer.
3. Install two 9V batteries into the external transformer (**fig. 4.4**).
4. Replace the battery door.

*NOTE: Always make sure the external transformer is equipped with two fresh 9V batteries, since the battery backup system does not recharge itself. Fresh batteries are defined as 9V alkaline batteries that are replaced every time the battery backup system is activated during a power failure, or once every six (6) months if the battery backup system has not been activated. For best performance, heavy duty or industrial strength alkaline or non-rechargeable lithium-ion 9V batteries should be used. Ensure that the marked battery door is replaced after installing new batteries. Failure to replace 9V batteries as recommended may result in your chair not operating in the event of a power failure.*

*NOTE: If you unplug your chair for an extended period of time (more than one hour), remove the batteries from the external transformer. The chair will draw power from the batteries even when it is not in use.*

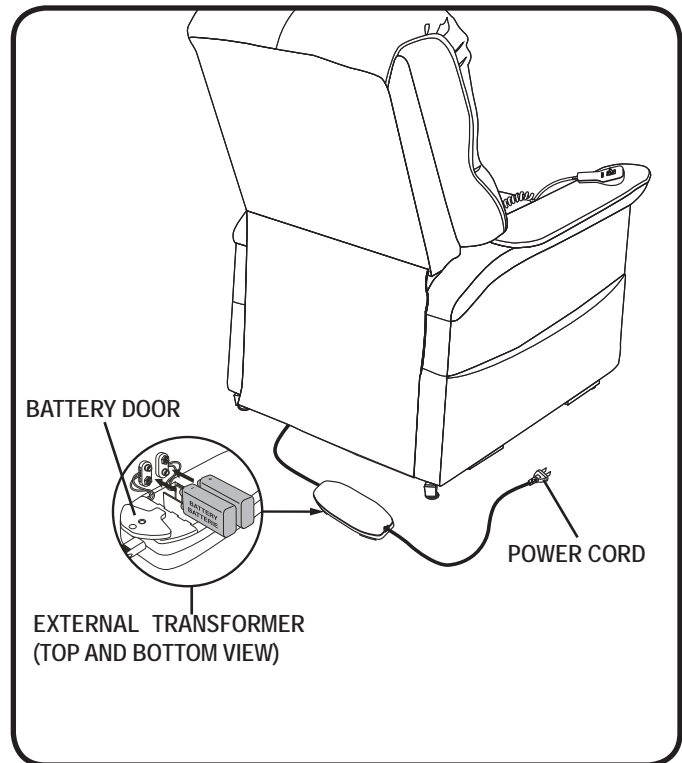

**Figure 4.4 Chair Battery Backup Location**

### Lithium-Ion Battery Pack Back-Up System

If your chair is equipped with an external transformer with a lithium-ion battery pack, your chair may be operated without being plugged into an electrical outlet for up to 48 hours.

**Follow these steps to replace the lithium-ion battery pack batteries:**

1. Unplug the external transformer power cord from the electrical outlet.
2. Position the external transformer so that the lithium-ion battery is facing upward (**fig. 4.6**).
3. Gently bump with your hand the end of the lithium-ion battery pack to dislodge it from external transformer.
4. Slide the lithium-ion battery until it stops and then lift the lithium-ion battery off of the external transformer.
5. Place the new lithium-ion battery on top of the external transformer with the securement grooves toward the external transformer (**fig. 4.6**).
6. Slide the new lithium-ion battery onto the external transformer until it clicks into place.

*NOTE: Remove the lithium-ion battery from the battery pack when your chair isn't being used for an extended period of time. The chair will draw power from the battery even when it is not in use.*

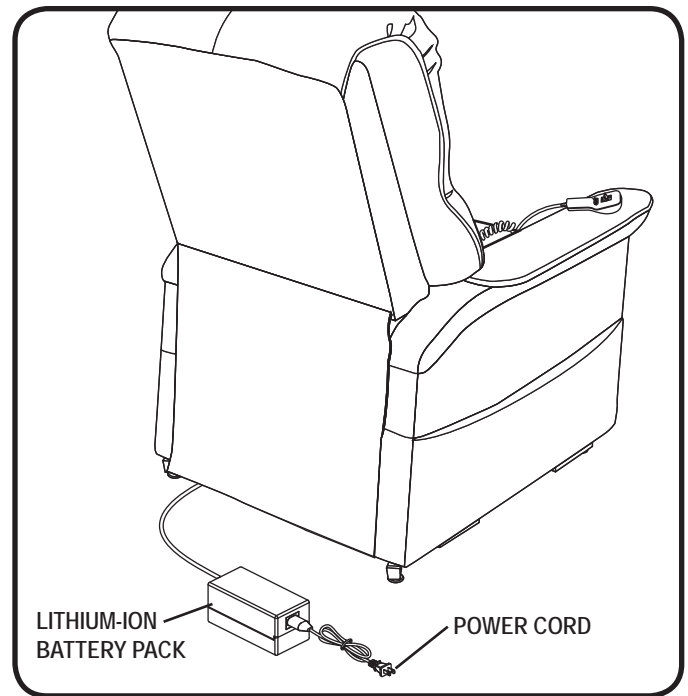

**Figure 4.5 Chair Battery Backup Location**

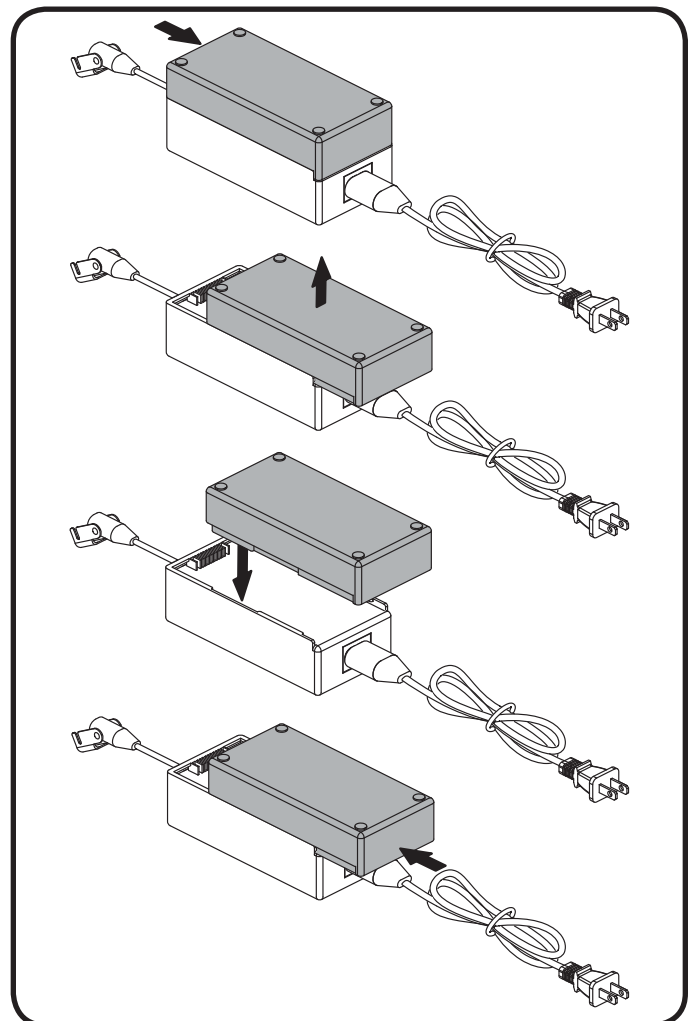

**Figure 4.6 Lithium-Ion Battery Replacement**

## V. OPERATION

---

### OPERATION PRECAUTIONS

There are certain precautions that should be taken during the operation of your chair. Read and follow these precautions carefully in order to ensure safe chair operation and to prevent injury and/or product damage.

- Plug the power cord directly into the electrical outlet. **Do not use an extension cord!**
- Do not place anything (for example, a drinking glass) on top of or near the external transformer.
- If the external transformer box or hand control requires cleaning, unplug the power cord from the electrical outlet and use a clean, dry cloth or lightly dampened cloth. Allow ample drying time before plugging the power cord back into the electrical outlet.
- Periodically check the hand control and all power cords for visible damage.
- Keep the hand control away from all heated surfaces.
- Ensure the hand control is out of the way before sitting in the chair.
- Keep children and pets away from all moving parts while operating the chair.
- Do not allow children to play on or operate the chair. Only the intended user should operate the chair.
- Keep the hand control locked or utilize the quick-disconnect feature on the standard hand control when the chair is not in use to prevent unintended operation of the chair. Store the hand control in the side pocket of your chair when not in use.
- Avoid pinch points, such as the lift and scissor mechanisms. Keep hands and feet clear of these areas.
- Always leave the chair in an upright and closed position when not in use.
- Do not sit or stand on the footrest.
- Do not “drop” into the chair when sitting if it is in a partially raised position.



PROHIBITED! Do not place objects under the chair. Make sure area is clear of obstructions, including pets and small children, during operation.

WARNING! Prevent the risk of electrical shock, fire, falls, and/or being pinched. Follow all instructions and precautions provided.



WARNING! Prevent potential equipment damage! Do not place the external transformer under the chair.

WARNING! Do not cover the external transformer. Keep the transformer in an open, well-ventilated area free from foreign material/debris to ensure proper operation.

### HAND CONTROL OPERATION

Your chair hand control is equipped with switches/buttons that control the movement of the chair and/or heat and massage options. Read the following instructions for basic hand control operation. Please refer to the Hand Control Quick Reference Guide for more detailed information on your specific hand control.

WARNING! Do not lean on or apply downward force to the chair-back when the chair is in the fully reclined position. Doing so could cause the chair to tip, resulting in personal injury and/or product damage. Store the hand control in the side pocket of your chair when not in use.



WARNING! Do not use the footrest as a seat, or for purposes outside its intended use. Doing so could cause instability in the chair and place undue stress on chair components, resulting in personal injury and/or product damage.

WARNING! Be sure to lock or disconnect the hand control when the chair is not in use.



**Follow these steps to properly sit in your chair:**

1. Make sure that the chair is in the standing position at the appropriate height for the user.
2. Back into the chair and sit in the center of the seat. Do not drop into the chair. Doing so may cause product damage or personal injury.
3. Activate the DOWN button (switch) to lower the chair to a comfortable seated position.

**Follow these basic steps to operate your chair from the seated position:**

1. Activate the UP button (switch) to raise your chair to the standing position.
2. Activate the DOWN button (switch) to lower the chair to a comfortable seated position.

**Follow these steps to recline your chair from the seated position:**

1. Activate and hold the DOWN button (switch) until comfortably reclined.
2. Activate and hold the UP button (switch) to return to an upright, seated position. Release the button (switch) when the chair reaches a comfortable seated position.

**Follow these steps to properly stand up from your chair:**

1. Activate and hold the UP button (switch) to raise your chair.
2. Release the button (switch) when the chair reaches a height where you can stand up comfortably.



WARNING! Do not attempt to stand up until you can stand safely, are steady on your feet, and can bear weight. We recommends the use of assistance aids and/or an attendant for enhanced stability.

WARNING! Avoid putting all of your weight on the chair armrests when attempting to stand and do not use the armrests for weight bearing purposes.

**Trendelenburg Position**

Elevate the footrest, and then recline the seatback until your feet are elevated higher from the ground than your head. Please refer to the Hand Control Quick Reference Guide for more detailed information on your specific hand control.

**“Zero Gravity” Position**

Elevate the footrest, and then recline the seatback until your thighs and lower legs are positioned slightly higher than your torso (body in V-like position). Please refer to the Hand Control Quick Reference Guide for more detailed information on your specific hand control.

## VI. BASIC TROUBLESHOOTING

Your chair may require occasional troubleshooting. The following troubleshooting tips and FAQs should summarize what you need to know about your chair. If at any time you do not feel comfortable performing the troubleshooting steps listed in this manual, contact your authorized provider for service. Please have the model number, serial number, and nature of the problem when calling.

### DUAL MOTOR TIMING

*NOTE: If your dual motor chair is equipped with a heat/massage option and/or was manufactured prior to May 17, 2011, and does not move when the hand control is pressed, the motors may be out-of-sync.*

#### Follow these steps to reset the motor timing:

1. Activate the hand control on the chair. If there is no movement in either direction, check if the motors are out-of-sync and that the pressure-sensitive safety switch has been activated. Out-of-sync motors will show one motor extended farther than the other and a pinched safety switch.
2. If the motors are out-of-sync, disconnect one of the two red safety switch plugs from the motor control box (**fig. 6.1**).
3. Activate the UP position on the hand control until your chair reaches the full lift position. This will reset the motor position and correct the timing (**fig. 6.1**).
4. Reconnect the red safety switch plug into the motor control box (**fig. 6.1**).

*NOTE: In order to preserve the correct motor timing, it is recommended to extend the chair to the full lift position when getting in and out of the chair.*

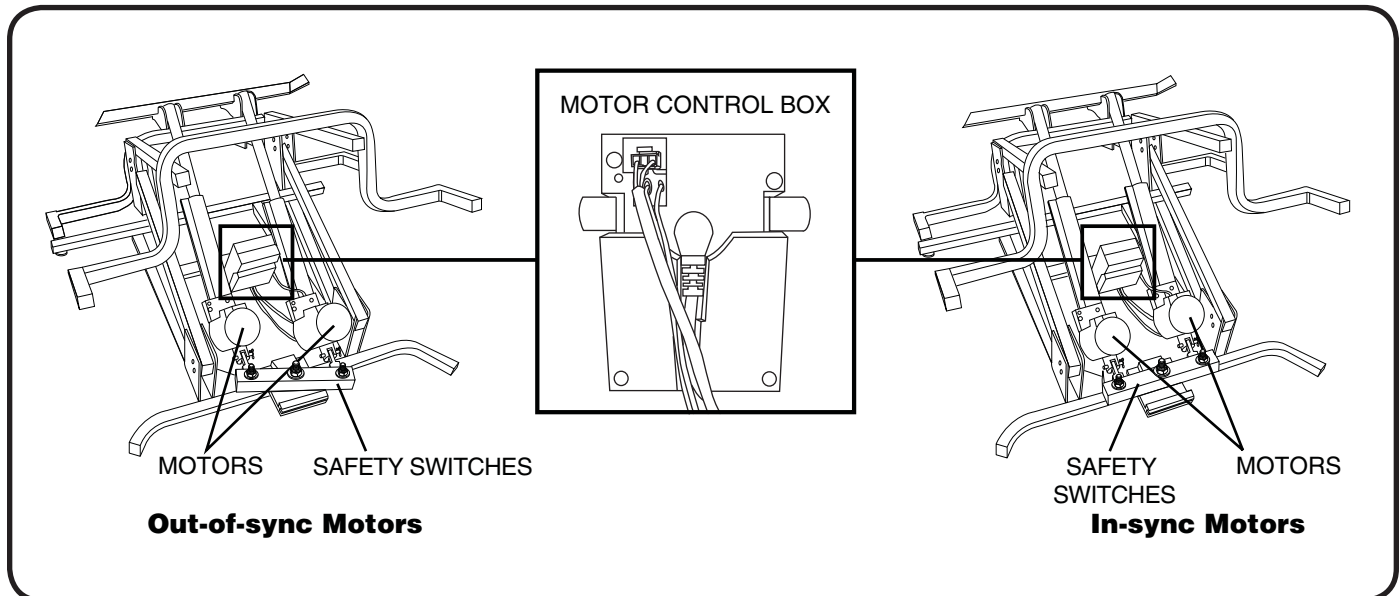

Figure 6.1 Dual Motor Timing

## FREQUENTLY ASKED QUESTIONS

### **What if my chair does not operate at all?**

- Ensure the external transformer is plugged into a properly wired electrical outlet.
- Check the circuit breaker box connected to the electrical outlet to ensure the outlet is receiving power.
- Ensure the low voltage connection cable is plugged into the external transformer.
- Ensure that all cables are connected properly.

### **What if my chair operates in one direction only?**

- Check the up and down buttons or toggle switch on the hand control to make sure they do not stick. If the buttons or switch are sticking in either position, the hand control may need to be replaced.
- Contact your authorized Provider for further assistance.

### **What if chair stops during a lifting cycle?**

- Your chair is equipped with an internal thermal shutoff switch located inside the external transformer that prevents the motor control box from overheating. If the thermal shutoff activates, allow the chair to remain in a stationary position for 10 minutes to allow the motor to cool, then resume normal operation. If you notice the motors overheating frequently, contact your authorized Provider.
- There may have been a power failure and/or there are no batteries in the external transformer or the batteries have no charge. Always make sure there are fresh 9V batteries in the external transformer if equipped with battery backup.
- Check the circuit breaker box connected to the electrical outlet to ensure the outlet is receiving power.

### **What if the heat and massage options on my chair do not function?**

- Ensure the junction box is connected properly to the external transformer and that there is power to the transformer. A green LED will light on the transformer to indicate power.
- Ensure the heat and massage units are connected properly at the rear of the chair.
- Ensure the hand control is connected properly to the chair. If connected properly, any LEDs on the hand control will be lit.
- If any of the LEDs do not light, contact your authorized Provider for further assistance.

### **What if my chair is rocking from corner to corner after I position the chair?**

The floor may be uneven or the carpet may be affecting chair position. Adjust the leg levelers in the area where the chair is rocking. See III. “Your Chair” for instructions on leveling your chair.

### **Where can I place the external transformer box?**

- On the floor away from heat sources in an open, well-ventilated area where it will not be an obstruction.
- On the wall away from heat sources using the optional external transformer wall mount. Refer to the Wall Mount Diagram Product Insert provided with your chair.

### **Where do I find the serial number on my chair?**

You can find the serial number in two locations—one is near the rear of the motor on the steel lift mechanism, the second is attached to the frame below the scissor mechanisms. The model number for your chair is printed below the serial number bar code.

### **Who do I call for service?**

Contact your authorized Provider for service.

## VII. CARE AND MAINTENANCE

---

Your chair will require routine maintenance checks. You can perform some of these checks, but others may require assistance from an authorized Provider. By following the maintenance checks in this section as scheduled, you can help ensure your chair gives you years of trouble-free operation. If you have any questions regarding your chair's care, contact your authorized Provider.

### FABRIC CARE

- Inspect the fabric on a regular basis for any pulls, tears, or gaps.
- Choose the right methods to clean the fabric on your chair. Before cleaning your chair, consult your authorized Provider for cleaning codes.

WARNING! Fabric should not be allowed to come in direct contact with any type of heat source (e.g., a space heater or lit tobacco products). Personal injury or fire damage may occur.



WARNING! Your Provider strongly recommends that you do not smoke lit tobacco products while seated in or using your chair, although the chair has passed the necessary testing requirements for smoking lit tobacco products. You must adhere to the following safety guidelines if you decide to smoke lit tobacco products while seated in or using your chair.

- Do not leave lit tobacco products unattended.
- Keep ashtrays a safe distance from the chair.
- Always make sure lit tobacco products are completely extinguished before disposal.

*NOTE: Do not use solvent-type cleaners to spot clean. Do not saturate the fabric. Prevent damage to the fabric; do not expose the chair to direct sunlight.*

### ELECTRONICS CARE

- Inspect all wiring harnesses to make sure they are not damaged or frayed.
- If damage is present, unplug the chair and contact your authorized Provider for service.
- Keep all electronics free from moisture and temperature extremes. **Chairs are intended for indoor use only!**



WARNING! Even though the chair has passed the necessary testing requirements for ingress of liquids, you should keep electrical connections and the external transformer away from sources of dampness, including direct exposure to water or bodily fluids and incontinence. Check electrical components frequently for signs of corrosion and replace as necessary.

WARNING! The external transformer should always be positioned so that the product specification information/name plate faces down. Improper placement may result in product or property damage.

### DISPOSAL AND RECYCLING

Your chair must be disposed of according to applicable local and national statutory regulations. Contact your local waste disposal agency or authorized provider for information on proper disposal of chair packaging, metal frame components, fabric, electronic components, and batteries.



WARNING! Plastic bags are a suffocation hazard. Dispose of plastic bags properly and do not allow children to play with them.

## **Questions & Answers about Proposition 65**

### **What is Proposition 65?**

Proposition 65 requires businesses to provide warnings to Californians about significant exposures to chemicals that cause cancer, birth defects, or other reproductive harm. These chemicals can be in the products that Californians purchase, in their homes or workplaces, or that are released into the environment. By requiring that this information be provided, Proposition 65 enables Californians to make informed decisions about their exposures to these chemicals.

Proposition 65 also prohibits California businesses from knowingly discharging significant amounts of listed chemicals into sources of drinking water. Proposition 65 requires California to publish a list of chemicals known to cause cancer, birth defects, or other reproductive harm. This list, which must be updated at least once a year, has grown to include approximately 900 chemicals since it was first published in 1987.

### **What types of chemicals are in the Proposition 65 list?**

The list contains a wide range of naturally occurring and synthetic chemicals that include additives or ingredients in pesticides, common household products, food, drugs, dyes, or solvents. Listed chemicals may also be used in manufacturing and construction, or they may be byproducts of chemical processes, such as motor vehicle exhaust.

### **What does a warning mean?**

If a warning is placed on a product label or posted or distributed at a workplace, a business, or in rental housing, the business issuing the warning is aware or believes that it is exposing individuals to one or more listed chemicals.

By law, a warning must be given for listed chemicals unless the exposure is low enough to pose no significant risk of cancer or is significantly below levels observed to cause birth defects or other reproductive harm.

### **Where can I get more information on Proposition 65?**

If you have specific questions on the administration or implementation of Proposition 65, you can contact OEHHA's Proposition 65 program at [P65.Questions@oehha.ca.gov](mailto:P65.Questions@oehha.ca.gov), or by phone at (916) 445-6900.

### **USER SAFETY NOTICE**

Your safety is important to us. If there is any information in this manual which you do not understand, or if you require additional assistance for setup or operation, please contact your authorized provider. **Failure to follow the instructions, warnings, and notes in this manual and those located on your product can result in personal injury or product damage and will void the product warranty.**





Your Chair has gone through a stringent inspection protocol to ensure our product is made to your satisfaction.

**Upholstery Workmanship**

**Aesthetics and Comfort**

**Performance**

**We keep a more detailed report on file at the factory.**



---

Model #

---

Date Inspected

---

Inspector

---

Serial #

UDI Label (if applicable)